

ABB motors  
Low voltage general performance motors  
for hazardous area



## The Leader in Motors

ABB is a global engineering and technology group serving customers in electrical power generation; transmission and distribution; automation; oil, gas and petrochemicals; industrial products and contracting; and financial services. The product range includes a full range of industrial electric motors, both AC and DC, LV and HV meeting the needs of most application, with virtually any power rating.

Within the Group, ABB Motors is the world's leading manufacturer of low-voltage induction motors, having over 100 years experience and a presence in more than 100 countries. ABB Motors's broad understanding of customer applications enables it to work closely to solve individual problems or to supply custom-designed motors for any project-no matter how demanding.

For customers, this all represents a solid value and commitment revealed in the dependable quality of ABB Motor's products and in its unrivalled customer service and back up. The hallmarks of its product are efficiency, robustness and reliability, combined to represent the best value available. Customers the world over rely on ABB Motors as the most solid and reliable supplier of electric motors. But above all, ABB Motors values its customers.

The best value is also enhanced by ABB Motors's worldwide customer service network guaranteeing fast delivery, rapid response and local back-up, as well as by worldwide ABB Service network supporting the after sales service.

ABB Motors has manufacturing facilities in Finland, Italy, Spain, Sweden, China and India. The comprehensive Motor stocks at each of these sites are reinforced by large and versatile stocks at Central Stock Nordic in Vasteras, Sweden; Central Stock, Europe in Menden, Germany and Central Stock Asia in Singapore, and by numerous distribution stocks.



## Making you more competitive

ABB has been manufacturing motors for over 100 years. Our products are designed to be reliable, efficient and cost effective, and we can supply motors for practically any application. A full range of services is available through our worldwide service organization, with the latest eBusiness systems providing round-the-clock access, easy ordering and fast delivery.

### M2000 motors

Our M2000 range offers quality motors, providing you with the ideal efficiency level for your needs. And our 24-hour availability helps make your life easier. Through our extended support and services such as eBusiness solutions and an efficient global stock concept, we provide you with easy ordering and quick delivery.



## Industrial

As a key element of its business strategy, ABB has committed to a broad program of product development and positioning under the Industrial<sup>IT</sup> umbrella. This initiative is geared towards increasing integration of ABB products as the "building blocks" of larger solutions, while incorporating functionality that will allow multiple products to interact seamlessly as components of real-time automation and information systems.

Motors and generators represent one of the fundamental building blocks in the Industrial<sup>IT</sup> architecture.

ABB ([www.abb.com](http://www.abb.com)) is a leader in power and automation technologies that enable utility and industry customers to improve performance while lowering environmental impacts. The ABB Group of companies operates in around 100 countries and employs about 107,000 peoples.

## ATEX Directives 94/9/EC (“95”) and 1999/92/EC (“137”)

ATEX Directives harmonize the safety rules in respect with the free trading principles of the European Community.

The responsibilities are split in two areas between the manufacturers and the end users. The manufacturers have to comply with the ‘Essential Health and Safety Requirements’ of the Products Directive 94/9/EC, or ATEX 95; and the end users must proceed to make an Explosion Protection Document based on risks assessment of their ‘work places’ and ‘work equipment’ to fulfil the ‘minimum requirements’ listed in the Worker Protection Directive 1999/92/EC or ATEX 137.

Motors comply fully with the ATEX product directive 94/9/EC. According to the regulations, low voltage motors for hazardous areas are exempted from the Low Voltage Directive, the EMC directive as well as the Machinery Directive.

IEC and the corresponding EN Standards are at the moment in a new process of renewal or revision. In general old and new standard or revision are both in parallel valid for about 3 years. This affects mostly the marking of the motor, occasionally also new technical requirements are introduced.

### ABB refers to recently updated standards

In the implementation of ATEX 95 and ATEX 137 directives ABB refers to the IEC and EN standards which have been recently updated. Otherwise ABB refers to IEC standards.

Main standards for implementation Worker Protection Directive 1999/92/EC (ATEX 137)	
IEC/EN 60079-10	Classification of hazardous areas (gas areas)
IEC/EN 61241-10	Classification of areas where combustible dusts are or may be present
IEC/EN 60079-14	Installation rules of gas equipment
IEC/EN 61241-14	Selection and Installation of Ex tD (DIP) equipment.
IEC/EN 60079-17	Electrical installations Inspection and maintenance
IEC/EN 60079-19	Equipment Repair and overhaul

### Motors for EU motor efficiency levels

A new Europe-wide agreement will ensure that the efficiency levels of electric motors manufactured in Europe are clearly displayed. In contrast to the American legislation on motor efficiency the European agreement does not establish mandatory efficiency levels. It basically establishes three classes giving motor manufacturers an incentive to qualify for a higher class.

ABB is one of only a handful of leading motor manufacturers in Europe, to have a motor range to meet or exceed the minimum efficiencies stated in the highest level of the EU agreement of LV motors.

#### EU efficiency classes for 2 pole motors.

Output KW	2-pole Boarderline	
	EFF2/EFF3	EFF1/1FF2
1.1	76.2	82.8
1.5	78.5	84.1
2.2	81.0	85.6
3	82.6	86.7
4	84.2	87.6
5.5	85.7	88.6
7.5	87.0	89.5
11	88.4	90.5
15	89.4	91.3
18.5	90.0	91.8
22	90.5	92.2
30	91.4	92.9
37	92.0	93.3
45	92.5	93.7
55	93.0	94.0
75	93.6	94.6
90	93.9	95.0

## IECEx Scheme

The IECEx Scheme is an International Certification Scheme covering both apparatus and services for explosive atmospheres, as the internationally accepted means of demonstrating claimed compliance with IEC standards. It comprises the following two international programs:

- IECEx Certified Equipment Program, covering Ex products
- IECEx Certified Service Facilities Program covering Ex Repair and Overhaul Workshops

It is a voluntary scheme which provides confidence that products and services covered by an IECEx certificate meet the specified requirements related to the hazardous area concerned (included Zone 2 / 22) as the internationally accepted means of demonstrating claimed compliance with an IEC Standard.

The management of this Scheme includes Certification Bodies of 26 countries around the world (experts, manufacturers, end users, regulators).

For more information please visit [www.iecex.com](http://www.iecex.com).

ABB is relying on the IECEx Scheme and a large range of Ex motors are tested and certified according to this.

#### Main standards complying with the “EHSR’s” of Products Directive 94/9/EC (ATEX 95)

EN 60079-0	General requirements for gas
EN 61241-0	General requirements for dust
EN 60079-1	Flame proof enclosure ‘d’
EN 60079-2	Pressurized enclosure ‘p’
EN 60079-7	Equipment protection by increased safety ‘e’
EN 60079-15	Construction test and marking of type of protection ‘n’
EN 61241-1	Protection by enclosure ‘tD’

These efficiency levels apply to 2-and-4-pole three phase squirrel cage induction motors rated for 400V, 50Hz with S1 duty class with the output 1.1 to 90kW, which account for the largest volume on the market.

The efficiency of motor from different manufacturers are collated in a database. EURODEEM, published by the European Commission. It is accessible over the internet at <http://jamest.jrc.it/projects/eem/eurodeem.htm>.

#### EU efficiency classes for 4 pole motors.

Output KW	4-pole Boarderline	
	EFF2/EFF3	EFF1/1FF2
1.1	76.2	83.8
1.5	78.5	85.0
2.2	81.0	86.4
3	82.6	87.4
4	84.2	88.3
5.5	85.7	89.2
7.5	87.0	90.1
11	88.4	91.0
15	89.4	91.8
18.5	90.0	92.2
22	90.5	92.6
30	91.4	93.2
37	92.0	93.6
45	92.5	93.9
55	93.0	94.2
75	93.6	94.7
90	93.9	95.0

## Hazardous areas

Hazardous areas worldwide are classified by zone, according to the risk posed by explosive gas or dust in the atmosphere.

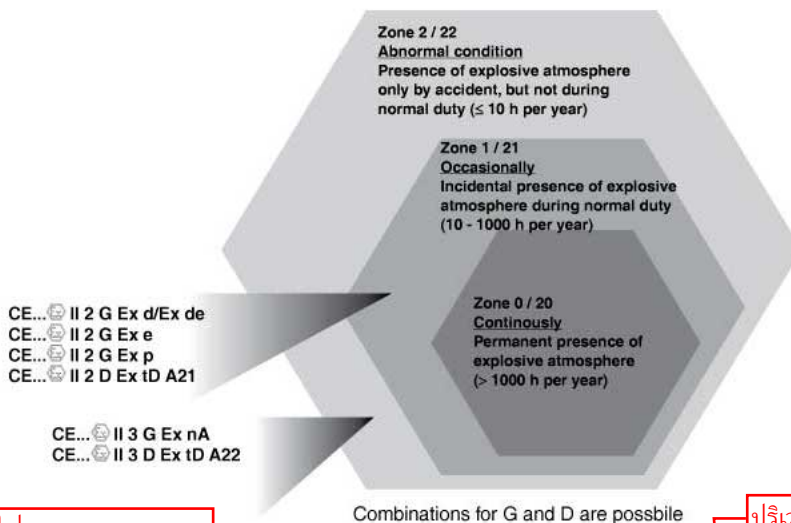
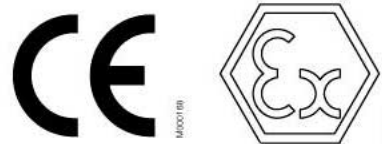

ฝุ่นติดไฟ

บริเวณนั้นมีแก๊ส ออกมาจากบริเวณมอเตอร์ไม่มีกี่ครั้ง ?

## Classification of hazardous locations according to CENELEC and IEC

The definition of areas according to the presence of atmosphere are set up in the following standards:

EN 60079-10	Gas
EN 61241-1	Dust
IEC 60079-10	Gas
IEC 61241-1	Dust

Explosive atmosphere	Permanent presence	Incidental presence (normal operation conditions)	Accidental presence (abnormal operation conditions)
Gas ('G')	Zone 0	Zone 1	Zone 2
Dust ('D' / 'DIP' / 'Ex tD')	Zone 20	Zone 21	Zone 22

Note: In certain countries Ex d and Ex e motors are also used in Zone 2.

## Marking temperatures, gas groups and hazardous areas

To ensure equipment can be safely used in potentially explosive atmospheres, the hazardous areas where the equipment is installed must be known. Temperature class of equipment must be compared with the spontaneous ignition temperature of the gas mixtures concerned and its gas group must be known in specific cases (e.g. flame proof protection).

### Categories or classification

The ATEX Directive has introduced the concept of "Categories" which is a way of expressing the capability of equipment respecting the EHSR versus the Zone where the equipment is installed.

Category 1	according to Annex 1 of ATEX 95 used in Zone 0 or Zone 20
Category 2	according to Annex 1 of ATEX 95 used in Zone 1 or 21
Category 3	according to Annex 1 of ATEX 95 used in Zone 2 or 22

## Classification

	Category equipment	Inflammable substances	Level of protection	Fault protection	Comparison with present practice and IEC
Equipment group I (mines)	M1	Methane, dust	Very high level	2 types of protection or 2 independent faults	Group I
	M2	Methane, dust	High level	1 type of protection Normal operation	Group I
Equipment group II (surface)	1	Gas, vapours, mist, dust	Very high level	2 types of protection or 2 independent faults	Group II Zone 0 (gas) / Zone 20 (dust)
	2	Gas, vapours, mist, dust	High level	1 type of protection Habitual frequent malfunction	Group II Zone 1 (gas) / Zone 21 (dust)
	3	Gas, vapours, mist, dust	Normal	Required level of protection	Group II Zone 2 (gas) / Zone 22 (dust)

## Temperature classes

Temperature class	Ignition temperature for the gas/vapour °C	Max. permitted temperature equipment °C
<b>T1</b>	> 450	450
<b>T2</b>	> 300 < 450	300
<b>T3</b>	> 200 < 300	200
<b>T4</b>	> 135 < 200	135
<b>T5</b>	> 100 < 135	100
<b>T6</b>	> 85 < 100	85

## Grouping of electrical apparatus

<b>Group I</b>	Apparatus for coal mines susceptible to firedamp
<b>Group II</b>	Apparatus for explosive atmospheres other than mines; surface industries
<b>IIA, IIB, IIC</b>	Group II is subdivided for Ex d and Ex i -equipment according to the severity of the environment. IIC is the highest rating; a motor from one of the higher categories can also be used in a lower category environment

## Marking of equipment

### Protection type marking:

**EEx according to the EN standards series 50000**

**Ex according to the EN standards series 60079 and 61241**

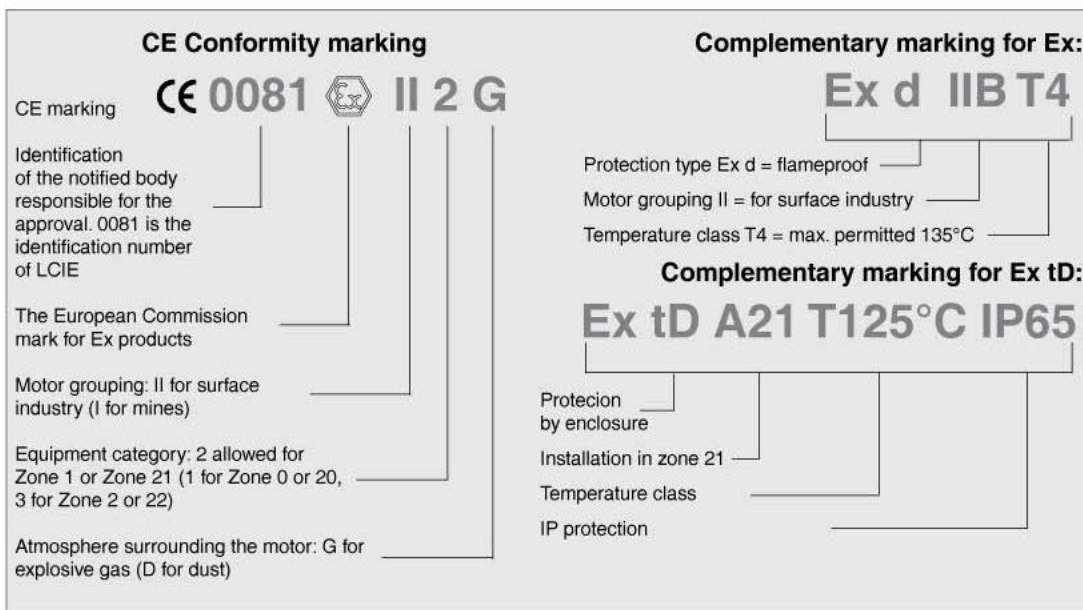

## Selection of products for hazardous areas

### EN Standard for Group II: Gas environments

### EN Standard for Group II: Dust environments

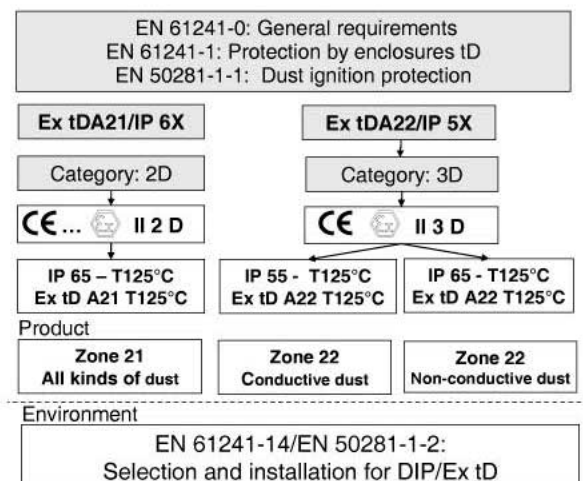
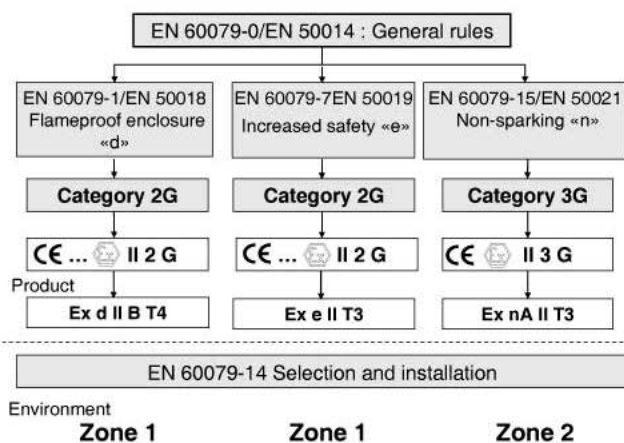

# General about hazardous areas

## Preamble

In hazardous areas, it is the utmost importance to ensure the safe use of electrical apparatus. To this end, many countries have regulations concerning both the design and use of such apparatus. These regulations are becoming increasingly harmonized within the framework of IEC recommendations and European Standards.

The hazard may be due to an explosive atmosphere composed of a mixture of gas, vapors or dusts with air. This chapter only deals with safety in explosive gas atmospheres for which European Standards exist. ABB has a full range of flameproof motors certified according to IECEx.

## Flameproof enclosure Ex d and Ex de



The motor enclosure shall be designed in such a way that no internal explosion can be transmitted to the explosive atmosphere surrounding the motor. The enclosure must withstand, without damage, any pressure levels caused by an internal explosion. The shape, length and gap of part assembly joints, at shaft opening, cable entries, etc., shall be designed to allow for throttling and cooling of hot gases escaping outside. The standards emphasize the impact of an explosive atmosphere (for instance, explosion pressure) over constructional requirements of such apparatus.

The temperature of the motor's external enclosure should not exceed the self-ignition temperature of the explosive atmosphere of the installation area during normal operation. For this reason, rated output depends on this rated maximum temperature for the considered area.

No motor device outside the flameproof enclosure (e.g., ventilation) shall be a potential source of sparks, arcs or dangerous overheating.

Variants combining two types of protection usually combine "d" and "e" protection. The most commonly used and recognized by the CENELEC European Standards is the Ex de variant. The motor is designed with an Ex d flameproof enclosure, while the terminal box features an Ex e increased safety protection. Such design combines the superior safety degree of the "d" type of protection with the less stringent electrical connection requirements of increased safety motors.

Motors featuring dual protection are seldom encountered - such as an increased safety motor with a flame-proof enclosure designated Ex e / Ex d in European Standards.

### EC Declaration of Conformity

**The Manufacturer:** ABB Shanghai Motors Co., Ltd  
N° 88 Tianhang Road, Minhang (Economic & Technical Development Zone)  
200245 - Shanghai, China

hereby declares that

**The Products:** 3-phase induction motors, series M2JA, M2GP - IEC shaft height 80 - 355, as listed on page 2 in this document, are in conformity with provisions of the following Council Directive:

**Directive 94/9/EC (ATEX of 23 March 1994).**

In respect of product categories the motors are in conformity with provisions of the following harmonized standards:

**For M2JA :** EN 60079-0 (2006), EN 60079-1 (2004)

A Notification LCIE 03 ATEX Q 8084 according to annex IV of Directive has been obtained and an EC-type examination certificate LCIE - ATEX ... has been delivered for each type designation listed on page 2 of this document

**For M2GP :** EN 60079-0 (2006), EN 60079-15 (2005)

A Type examination certificate LCIE - ATEX ... listed on page 2 of this document has been obtained.

Changes of the newest revisions of above standards do not effect the construction of the listed motors, which thus comply with the Essential Health and Safety Requirements in Annex II of said directive.

**Note:**  
The motor range listed have been certified according to old EN Standards range (EN 50014 / EN50018 & EN 50021).  
According to decision of "ATEX European Standing Committee", and after consulting Notified Bodies, ABB is going to continue with the process already started to move the motor certifications from EN 500XX series of standards to EN 60079-0 / EN 60079-1 / EN 60079-15

The Notified Body responsible for monitoring the ATEX Directive is LCIE Fontenay Aux Roses France. Identification number 0081.

Signed by 

Title: Jarvis-Li Xu  
Chief Engineer, Manager, Technical & Quality Control Dept.

Date: January 19<sup>th</sup>, 2009

ABB Shanghai Motors

---

N° 88 Tianhang Road, Minhang (Economic & Technical Development Zone) 200245 Shanghai, China











Telephone: +86 21 5472 3133  
e-mail: first name last name @cn.abb.com  
Telefax: +86 21 5472 5025

Internet: www.abb.com.cn



<p>(A1) ANNEXE</p> <p>(A2) ATTESTATION D'EXAMEN CE DE TYPE</p> <p style="text-align: center;">LCIE 04 ATEX 6106</p> <p>(A3) Description de l'équipement ou du système de protection :</p> <p style="text-align: center;">Moteur triphasé à courant alternatif Type : M2JA315...</p> <p>Moteur asynchrone avec carcasse antidéflagrante et boîte à bornes antidéflagrante.</p> <p>Ce certificat concerne les types suivants: M2JA315S2A, M2JA315M2A, M2JA315L2A, M2JA315L2B, M2JA315S4A, M2JA315M4A, M2JA315L4A, M2JA315L4B, M2JA315S6A, M2JA315M6A, M2JA315L6A, M2JA315L6B, M2JA315S8A, M2JA315M8A, M2JA315L8A, M2JA315L8B.</p> <p>M2JA : Gamme des moteurs EEx d 315 : Hauteur d'axe M : Dimension montage carcasse 2 : Nombre de pôles A : Longueur de la carcasse</p> <p>Le démarrage direct en dessous de la gamme de température -40°C à +20°C est interdit. Des mesures appropriées doivent être prises pour préchauffer le moteur et garder la température de l'enveloppe du moteur au-dessus de +20°C par des résistances et le chauffage du bobinage par une alimentation basse tension pendant un certain temps. Ce courant se produisant dans les enroulements réchauffera pas le courant défini sur la plaque signalétique.</p> <p>Les paramètres électriques sont les suivants :</p> <p>Tension nominale : 380-690V, 50Hz 440-480V, 60Hz</p> <p>Service : S1</p> <p>Variations électriques et mécaniques définies dans les documents descriptifs du constructeur (voir A4).</p> <p>Le marquage est le suivant :</p> <p>ABB Motors Adresse Type : M2JA315... n° de fabrication Année de fabrication Ⓢ II 2 G EEx d IIC T1 to T5 LCIE 04 ATEX 6106 - Caractéristiques électriques (U<sub>n</sub> ... V, I<sub>n</sub> ... A, P<sub>n</sub> ... kW, F ... Hz, n/min ... Cos φ ...) NE PAS OUVRIER SOUS TENSION (sur le couvercle)</p> <p>Le marquage CE est accompagné du numéro d'identification de l'organisme notifié responsable de la surveillance du système de qualité (0081 pour le LCIE)</p> <p>Le matériel devra également comporter le marquage normalement prévu par les normes de construction du matériel électrique concerné.</p>	<p>(A1) SCHEDULE</p> <p>(A2) EC TYPE EXAMINATION CERTIFICATE</p> <p style="text-align: center;">LCIE 04 ATEX 6106</p> <p>(A3) Description of Equipment or Protective System:</p> <p style="text-align: center;">Three-phase AC motor Type : M2JA315...</p> <p>Asynchronous motor with flameproof frame and flameproof terminal box.</p> <p>This certificate covers the following types: M2JA315S2A, M2JA315M2A, M2JA315L2A, M2JA315L2B, M2JA315S4A, M2JA315M4A, M2JA315L4A, M2JA315L4B, M2JA315S6A, M2JA315M6A, M2JA315L6A, M2JA315L6B, M2JA315S8A, M2JA315M8A, M2JA315L8A, M2JA315L8B.</p> <p>M2JA : EEx d motor series 315 : Frame size M : Frame mounting dimension 2 : Pole number A : Frame length</p> <p>Direct starting under range -40°C to +20°C is prohibited.</p> <p>Appropriate measures should be taken to preheat motors to keep the temperature on the motor enclosure above +20°C by space heaters and heating stator windings with low voltage supply for a certain time. This direct current generating in the windings shall not exceed the rated current on the nameplate.</p> <p>The electrical parameters are the following :</p> <p>Rated voltage : 380-690V, 50Hz 440-480V, 60Hz</p> <p>Duty : S1</p> <p>Electrical and mechanical variations are defined within the descriptive documents established by the manufacturer (see A4).</p> <p>The marking is the following :</p> <p>ABB Motors Address Type : M2JA315... Serial number Year of construction : Ⓢ II 2 G EEx d IIC T1 to T5 LCIE 04 ATEX 6106 Electrical characteristics (U<sub>n</sub> ... V, I<sub>n</sub> ... A, P<sub>n</sub> ... kW, F ... Hz, r/min ... Cos φ ...) DO NOT OPEN WHILE ENERGIZED (on cover)</p> <p>The CE marking shall be accompanied by the identification number of the notified body responsible for surveillance of the approved quality system (0081 for LCIE)</p> <p>The equipment must also carry the usual marking required by the manufacturing standards applying to such equipments.</p>
--	--

Page 2/3

 <p><b>1 ATTESTATION D'EXAMEN CE DE TYPE</b></p> <p>2 Appareils et systèmes de protection destinés à être utilisés en atmosphères explosibles Directive 94/9/CE</p> <p>3 Numéro de l'attestation CE de type LCIE 04 ATEX 6106</p> <p>4 Appareil ou système de protection : Moteur triphasé à courant alternatif Type : M2JA315...</p> <p>5 Demandeur : ABB Shanghai Motors Co. Ltd</p>	 <p><b>1 ATTESTATION D'EXAMEN CE DE TYPE</b></p> <p>2 Appareils et systèmes de protection destinés à être utilisés en atmosphères explosibles Directive 94/9/CE</p> <p>3 Numéro de l'attestation CE de type LCIE 04 ATEX 6106</p> <p>4 Appareil ou système de protection : Moteur triphasé à courant alternatif Type : M2JA315...</p> <p>5 Demandeur : ABB Shanghai Motors Co. Ltd</p>	 <p><b>1 ATTESTATION D'EXAMEN CE DE TYPE</b></p> <p>2 Appareils et systèmes de protection destinés à être utilisés en atmosphères explosibles Directive 94/9/CE</p> <p>3 Numéro de l'attestation CE de type LCIE 04 ATEX 6106</p> <p>4 Appareil ou système de protection : Moteur triphasé à courant alternatif Type : M2JA315...</p> <p>5 Demandeur : ABB Shanghai Motors Co. Ltd</p>	 <p><b>1 EC TYPE EXAMINATION CERTIFICATE</b></p> <p>2 Equipment or protective system intended for use in potentially explosive atmospheres Directive 94/9/EC</p> <p>3 EC type Examination Certificate number LCIE 04 ATEX 6106</p> <p>4 Equipment or protective system : Three-phase AC motor Type : M2JA315...</p> <p>5 Applicant : ABB Shanghai Motors Co. Ltd</p>
 <p><b>1 ATTESTATION D'EXAMEN CE DE TYPE</b></p> <p>2 Appareils et systèmes de protection destinés à être utilisés en atmosphères explosibles Directive 94/9/CE</p> <p>3 Numéro de l'attestation CE de type LCIE 04 ATEX 6106</p> <p>4 Appareil ou système de protection : Moteur triphasé à courant alternatif Type : M2JA315...</p> <p>5 Demandeur : ABB Shanghai Motors Co. Ltd</p> <p>6 Adresse : 8 Guang Xing Rd., Rong Bei Twon Songjiang District, Shanghai - CHINA</p> <p>7 Cet appareil ou système de protection et ses variantes éventuelles acceptées est décrit dans l'annexe de la présente attestation et dans les documents descriptifs cités en annexe.</p> <p>8 La LCIE, organisme notifié sous la référence 0081 conformément à l'article 9 de la directive 94/9/CE du Parlement européen et du Conseil du 23 mars 1994, certifie que cet appareil ou système de protection est conforme aux exigences essentielles en ce qui concerne la sécurité et la santé pour la conception et la construction d'appareils et de systèmes de protection destinés à être utilisés en atmosphères explosibles, données dans l'annexe II de la directive. Les vérifications et épreuves figurent dans notre rapport confidentiel N° 60024635-518806-12.</p>	 <p><b>1 ATTESTATION D'EXAMEN CE DE TYPE</b></p> <p>2 Appareils et systèmes de protection destinés à être utilisés en atmosphères explosibles Directive 94/9/CE</p> <p>3 Numéro de l'attestation CE de type LCIE 04 ATEX 6106</p> <p>4 Appareil ou système de protection : Moteur triphasé à courant alternatif Type : M2JA315...</p> <p>5 Demandeur : ABB Shanghai Motors Co. Ltd</p> <p>6 Adresse : 8 Guang Xing Rd., Rong Bei Twon Songjiang District, Shanghai - CHINA</p> <p>7 Cet appareil ou système de protection et ses variantes éventuelles acceptées est décrit dans l'annexe de la présente attestation et dans les documents descriptifs cités en annexe.</p> <p>8 La LCIE, organisme notifié sous la référence 0081 conformément à l'article 9 de la directive 94/9/CE du Parlement européen et du Conseil du 23 mars 1994, certifie que cet appareil ou système de protection est conforme aux exigences essentielles en ce qui concerne la sécurité et la santé pour la conception et la construction d'appareils et de systèmes de protection destinés à être utilisés en atmosphères explosibles, données dans l'annexe II de la directive. Les vérifications et épreuves figurent dans notre rapport confidentiel N° 60024635-518806-12.</p>	 <p><b>1 ATTESTATION D'EXAMEN CE DE TYPE</b></p> <p>2 Appareils et systèmes de protection destinés à être utilisés en atmosphères explosibles Directive 94/9/CE</p> <p>3 Numéro de l'attestation CE de type LCIE 04 ATEX 6106</p> <p>4 Appareil ou système de protection : Moteur triphasé à courant alternatif Type : M2JA315...</p> <p>5 Demandeur : ABB Shanghai Motors Co. Ltd</p> <p>6 Adresse : 8 Guang Xing Rd., Rong Bei Twon Songjiang District, Shanghai - CHINA</p> <p>7 Cet appareil ou système de protection et ses variantes éventuelles acceptées est décrit dans l'annexe de la présente attestation et dans les documents descriptifs cités en annexe.</p> <p>8 La LCIE, organisme notifié sous la référence 0081 conformément à l'article 9 de la directive 94/9/CE du Parlement européen et du Conseil du 23 mars 1994, certifie que cet appareil ou système de protection est conforme aux exigences essentielles en ce qui concerne la sécurité et la santé pour la conception et la construction d'appareils et de systèmes de protection destinés à être utilisés en atmosphères explosibles, données dans l'annexe II de la directive. Les vérifications et épreuves figurent dans notre rapport confidentiel N° 60024635-518806-12.</p>	 <p><b>1 EC TYPE EXAMINATION CERTIFICATE</b></p> <p>2 Equipment or protective system intended for use in potentially explosive atmospheres Directive 94/9/EC</p> <p>3 EC type Examination Certificate number LCIE 04 ATEX 6106</p> <p>4 Equipment or protective system : Three-phase AC motor Type : M2JA315...</p> <p>5 Applicant : ABB Shanghai Motors Co. Ltd</p>
 <p><b>1 ATTESTATION D'EXAMEN CE DE TYPE</b></p> <p>2 Appareils et systèmes de protection destinés à être utilisés en atmosphères explosibles Directive 94/9/CE</p> <p>3 Numéro de l'attestation CE de type LCIE 04 ATEX 6106</p> <p>4 Appareil ou système de protection : Moteur triphasé à courant alternatif Type : M2JA315...</p> <p>5 Demandeur : ABB Shanghai Motors Co. Ltd</p> <p>6 Adresse : 8 Guang Xing Rd., Rong Bei Twon Songjiang District, Shanghai - CHINA</p> <p>7 Cet appareil ou système de protection et ses variantes éventuelles acceptées est décrit dans l'annexe de la présente attestation et dans les documents descriptifs cités en annexe.</p> <p>8 Le LCIE, organisme notifié sous la référence 0081 conformément à l'article 9 de la directive 94/9/CE du Parlement européen et du Conseil du 23 mars 1994, certifie que cet appareil ou système de protection est conforme aux exigences essentielles en ce qui concerne la sécurité et la santé pour la conception et la construction d'appareils et de systèmes de protection destinés à être utilisés en atmosphères explosibles, données dans l'annexe II de la directive. Les vérifications et épreuves figurent dans notre rapport confidentiel N° 60024635-518806-12.</p> <p>9 Le respect des exigences essentielles en ce qui concerne la sécurité et la santé est assuré par la conformité aux documents suivants : - EN 50014 (1997) + amendements 1 et 2 - EN 50018 (2000)</p> <p>10 Le signe X lorsqu'il est placé à la suite du numéro de l'attestation, indique que ce matériel ou système de protection est soumis aux conditions spéciales pour une utilisation sûre, mentionnées dans l'annexe de la présente attestation.</p> <p>11 Cette attestation d'examen CE de type concerne uniquement la conception et la construction de l'appareil ou du système de protection spécifié, conformément à la directive 94/9/CE. Des exigences supplémentaires de cette directive sont applicables pour la fabrication et la fourniture de l'appareil ou du système de protection.</p> <p>12 Le marquage de l'appareil ou du système de protection devra comporter, entre autres indications utiles, les mentions suivantes : EEx d IIC T1 à T5 Fontenay-aux-Roses, le 20 septembre 2004</p>		 <p><b>1 EC TYPE EXAMINATION CERTIFICATE</b></p> <p>2 Equipment or protective system intended for use in potentially explosive atmospheres Directive 94/9/EC</p> <p>3 EC type Examination Certificate number LCIE 04 ATEX 6106</p> <p>4 Equipment or protective system : Three-phase AC motor Type : M2JA315...</p> <p>5 Applicant : ABB Shanghai Motors Co. Ltd</p> <p>6 Address : 8 Guang Xing Rd., Rong Bei Twon Songjiang District, Shanghai - CHINA</p> <p>7 This equipment or protective system and any acceptable variation thereto is specified in the schedule to this certificate and the documents therein referred to.</p> <p>8 LCIE, notified body number 0081 in accordance with article 9 of the Directive 94/9/EC of the European Parliament and Council of 23 March 1994, certifies that this equipment or protective system has been found to comply with the essential Health and Safety Requirements relating to the design and construction of equipment and protective system intended for use in potentially explosive atmospheres, given in Annex II of the Directive. The examination and test results are recorded in confidential report No 60024635-518806-12.</p> <p>9 Compliance with the Essential Health and Safety Requirements has been assured by compliance with : - EN 50014 (1997) + amendments 1 and 2 - EN 50018 (2000)</p> <p>10 If the sign X is placed after the certificate number, it indicates that the equipment or protective system is subject to special conditions for safe use specified in the schedule to this certificate.</p> <p>11 This EC Type examination certificate relates only to the design and construction of this specified equipment or protective system in accordance with the Directive 94/9/EC. Further requirements of the Directive apply to the manufacture and supply of this equipment or protective system.</p> <p>12 The marking of the equipment or protective system shall include the following : EEx d IIC T1 to T5 Le Directeur de l'organisme certificateur Manager of the certification body</p> <p>Page 1/3</p>	

## Mechanical design

### Totally enclosed, fan cooled IP55

Heavy duty design, manufactured from extra corrosion resistant cast iron materials to be used in all kind of environment. The motor is mechanically very strong and robust and as standard designed for additional energy saving through frequency converter drives.

### Flexible cable entry direction

Terminal boxes are mounted on the top of the motors, right or left. Terminal boxes of motor size 71-132 can rotate 4x90°, and those of 160-355 can rotate 2x180°. All are easy to refit.

### Powerful refit available

The motors satisfy the requirements of a wide range of environments and applications, such as improving protection, insulation level, regreasing facilities, dust-proof, sealing rings, rainproof are available, a full range of options are listed in page 13.

## Insulation and insulation classes

According to IEC60085, insulating materials are divided into insulation classes. Each class has a designation corresponding to the temperature that is the upper limit of the range of application of the insulating material under normal operating condition.

The winding insulation of a motor is determined on the basis of the temperature rise in the motor and the ambient temperature. The insulation is normally dimensioned for the hottest point in the motor at its normal rated output and at ambient temperature of 40°C. Motors subjected to ambient temperatures above 40°C will generally have to be derated. In most cases, the standard rated outputs of motors from ABB Motors are based on the temperature rise for insulation classes B. Where the temperature rise is according to class F, this is specified in the data tables.

However, all the motors are designed with class F insulation, which permits a higher temperature rise than class B. The motors, therefore, have a generous over-load margin. If temperature rise to class F is allowed, the outputs given in the tables can generally be increased by about 12 %

Temperature limits are according to standards. The extra thermal margin when using class F insulation with class B temperature rise makes the motors more reliable.

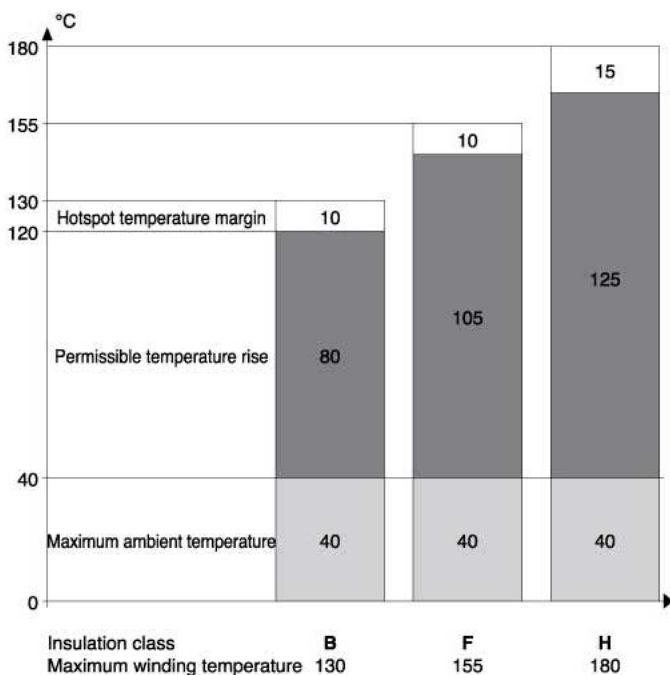

Safety margins per insulation class

## Mounting arrangements

### Foot-mounted motor

IM B3 IM1001 IM V5 IM1011 IM V6 IM1031 IM B6 IM1051 IM B7 IM1061 IM B8 IM1071

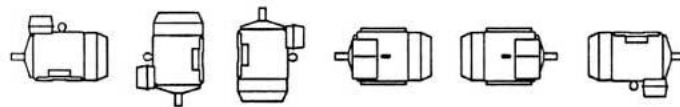

### Flange-mounted motor, large flange

IM B5 IM3001 IM V1 IM3011 IM V3 IM3031 \*) IM3051 \*) IM3061 \*) IM3071

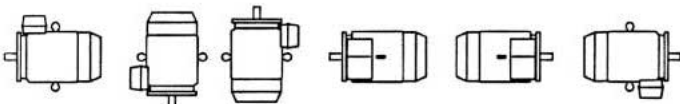

### Flange-mounted motor, small flange

IM B14 IM3601 IM V18 IM3611 IM V19 IM3631 \*) IM3651 \*) IM3661 \*) IM3671

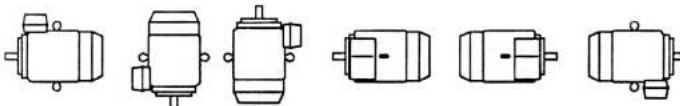

### Foot-and flange-mounted motor with feet, large flange

IM B35 IM2001 IM V15 IM2011 IM V36 IM2031 \*) IM2051 \*) IM2061 \*) IM2071

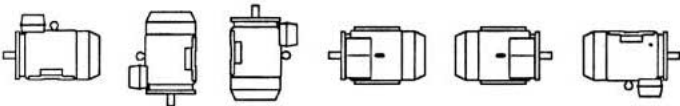

### Foot-and flange-mounted motor with feet, small flange

IM B34 IM2101 IM2111 IM2131 IM2131 IM2161 IM2171

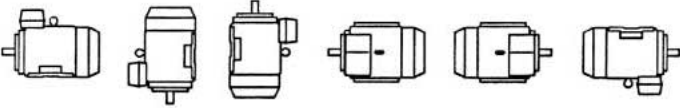

### Foot-mounted motor, shaft with free extensions

IM1002 IM1012 IM1032 IM1052 IM1062 IM1072

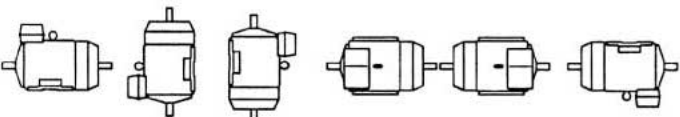

\*) Not stated in IEC 60034-7

### Product code pos.12

A = foot-mounted, term. box top  
 L = foot-mounted, term. box LHS  
 R = foot-mounted, term. box RHS  
 H = foot/flange-mounted, term. box top  
 J = foot/flange-mounted, small flange  
 B = flange mounted, large flange  
 C = flange mounted, small flange  
 T = foot/flange -mounted, term. box LHS  
 S = foot/flange-mounted, term. box RHS



## Motors for other voltages

Motors wound for a given voltage at 50Hz can also be used for other voltages. Recalculation factors for current and torque given are beside; efficiency, power factor and speed remain approximately the same. Guaranteed values available on request.

ABB Motors reserve the right to change the design, technical specification and dimensions without prior notice.

Motor wound for	230V	400V	500V	690V
Connected to 50Hz	220V 230V	380V 415V	500V 550V	660V 690V
% of values at 400V, 50Hz				
Output	100	100	100	100
$I_N$	182	174	105	98
$I_S/I_N$	90	100	90	106
$T_S/T_N$	90	100	90	106
$I_{MAX}/T_N$	90	100	90	106

Motors wound for certain voltage at 50 Hz can be operated at 60 Hz, without modification, subject to the following changes in their data.

Motor wound for 50Hz	220V	380V
Connected to 60Hz	220V	380V 415V 440V 460V
Data at 60Hz in percentage of values at 50Hz		
Output	100	100 110 115 120
r/min	120	120 120 120 120
$I_N$	98	98 98 100 100
$I_S/I_N$	83	83 83 95 100 105
$T_N$	83	83 83 91 96 100
$T_S/T_N$	70	70 70 85 95 100
$I_{MAX}/T_N$	85	85 85 93 98 103

## Bearings and terminal boxes

The motors are normally fitted with single-row deep groove ball bearings as listed in the table below. Degree of protection of the standard terminal box is IP55. The motors are supplied with 2 cable entries as standard according to the table below.

Terminal boxes are mounted on top of the motor. The terminal box of motor sizes 71 to 132 can be turned 4 x 90° and in motors sizes 160 to 355 rotated 2 x 180°.

Type	Poles	Standard bearing type		Cable entry	
		D-end	N-end	Main	Auxiliary*
80M	2,4,6	6202 DDUC3C3	6202 DDUC3C3	1-M25X1.5	2-M20X1.5
90S	2,4,6	6205 DDUC3C3	6205 DDUC3C3	1-M25X1.5	2-M20X1.5
90L	2,4,6	6205 DDUC3C3	6205 DDUC3C3	1-M25X1.5	2-M20X1.5
100L	2,4,6,8	6206 DDUC3C3	6206 DDUC3C3	1-M32X1.5	2-M20X1.5
112M	2,4,6,8	6207 DDUC3C3	6207 DDUC3C3	1-M32X1.5	2-M20X1.5
132S	2,4,6,8	6208 DDUC3C3	6208 DDUC3C3	1-M32X1.5	2-M20X1.5
132M	2,4,6,8	6208 DDUC3C3	6208 DDUC3C3	1-M32X1.5	2-M20X1.5
160M	2,4,6,8	6309 C3	6309 C3	2-M40X1.5	1-M20X1.5
160L	2,4,6,8	6309 C3	6309 C3	2-M40X1.5	1-M20X1.5
180M	2,4,6,8	6310 C3	6309 C3	2-M40X1.5	1-M20X1.5
180L	2,4,6,8	6310 C3	6309 C3	2-M40X1.5	1-M20X1.5
200L	2,4,6,8	6312 C3	6310 C3	2-M50X1.5	2-M20X1.5
225S	2,4,6,8	6313 C3	6312 C3	2-M50X1.5	2-M20X1.5
225M	2,4,6,8	6313 C3	6312 C3	2-M50X1.5	2-M20X1.5
250M	2,4,6,8	6315 C3	6313 C4	2-M63X1.5	2-M20X1.5
280S 2		6316 C4	6316 C3	2-M63X1.5	2-M20X1.5
280S 4,6,8		6316 C3	6316 C4	2-M63X1.5	2-M20X1.5
280M 2		6316 C4	6316 C3	2-M63X1.5	2-M20X1.5
280M 4,6,8		6316 C3	6316 C4	2-M63X1.5	2-M20X1.5
315S 2		6316 C4	6316 C3	2-M63X1.5	2-M20X1.5
315S 4,6,8		6319 C3	6316 C4	2-M63X1.5	2-M20X1.5
315M 2		6316 C4	6316 C3	2-M63X1.5	2-M20X1.5
315M 4,6,8		6319 C3	6316 C4	2-M63X1.5	2-M20X1.5
315L 2		6316 C4	6316 C3	2-M63X1.5	2-M20X1.5
315L 4,6,8		6319 C3	6316 C4	2-M63X1.5	2-M20X1.5
355M 2		6319MC4	6319MC3	2-M80X1.5	2-M20X1.5
355M 4,6,8		6322 C3	6319 C4	2-M80X1.5	2-M20X1.5
355L 2		6319MC4	6319MC3	2-M80X1.5	2-M20X1.5
355L 4,6,8		6322 C3	6319	2-M80X1.5	2-M20X1.5

## Motors of terminal boxes:

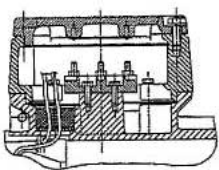

Terminal box for motor sizes 80 - 132

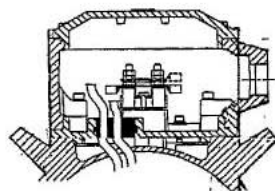

Terminal box for motor sizes 160 - 180

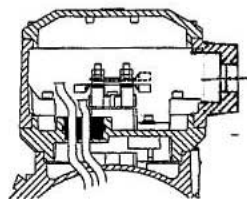

Terminal box for motor sizes 200 - 280

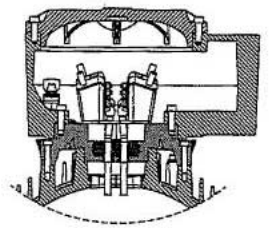

Terminal box for motor sizes 315 - 355

## Permissible loadings on the shaft end

The tables below give the permissible radial force in Newton, assuming zero axial force. The values are based on normal conditions at 50 Hz and calculated bearing lives for motor sizes 71 to 355 of 20000 hours and 40000 hours.

Motors are foot-mounted IM B3 version with force directed sideways. In some cases the strength of the shaft affects the permissible forces.

At 60 Hz the values must be reduced by 10%. For two-speed motors, the values must be based on the higher speed.

Permissible loads of simultaneous radial and axial forces will be supplied on request.

### Permissible radial forces

Motor size 71 to 355

20000 hours Ball bearings								
Motor size	2-pole		4-pole		6-pole		8-pole	
	X <sub>0</sub> N	X <sub>max</sub> N	X <sub>0</sub> N	X <sub>max</sub> N	X <sub>0</sub> N	X <sub>max</sub> N	X <sub>0</sub> N	X <sub>max</sub> N
71M	381.1	322.2	479.6	405.4	555.1	469.2	-	-
80M	624.2	509.4	788.3	643.3	906.7	739.9	996.7	813.4
90S	686.0	542.2	869.5	687.2	1000.1	790.4	1095.4	865.8
90L	696.4	564.2	884.7	716.8	1015.1	822.5	1112.0	901.0
100L	979.4	784.8	1233.9	988.8	1419.1	1137.2	1565.7	1254.6
112M	1257.8	1014.4	1592.1	1283.9	1831.1	1476.7	2020.1	1629.1
132S	1435.0	1121.7	1820.5	1423.1	2079.1	1625.3	2299.1	1797.2
132M	-	-	1840.2	1476.3	2106.5	1689.9	2329.4	1868.7
160M	1544.0	1199.8	1947.5	1513.4	2231.9	1734.4	2465.0	1615.6
160L	1562.7	1242.9	1971.2	1567.8	2259.0	1796.7	2495.0	1984.4
180M	2983.6	2371.3	3759.1	2987.7	-	-	-	-
180L	-	-	3801.5	3073.0	4351.6	3517.7	4800.4	3880.5
200L	4089.8	3376.8	5161.5	4261.7	5908.5	4878.5	6517.9	5381.7
225S	-	-	5762.8	4526.4	-	-	7260.7	5702.9
225M	4591.0	3811.1	5790.9	4594.2	6643.9	5271.0	7296.0	5788.4
250M	5111.6	4170.0	6439.9	5253.6	7388.1	6027.2	8113.0	6618.5
280S	6000.2	4956.7	7570.1	6253.5	8679.2	7169.8	9537.5	7878.8
280M	6048.5	5059.3	7631.5	6383.4	8750.0	7318.9	9615.4	8042.8
315S	6602.4	5627.1	9533.5	7882.0	10916.1	9025.1	12028.5	9944.8
315M	6677.1	5793.3	9647.8	8145.0	11047.2	9326.4	12173.2	10277.0
315L	6675.9	5792.3	9648.0	8145.1	11045.3	9324.7	12171.2	10275.3
355M	8280.0	6790.0	14060.0	11529.0	16089.0	13193.0	-	-
355L	8372.0	6865.0	14136.0	11592.0	16175.0	13264.0	-	-

40000 hours Ball bearings								
Motor size	2-pole		4-pole		6-pole		8-pole	
	X <sub>0</sub> N	X <sub>max</sub> N	X <sub>0</sub> N	X <sub>max</sub> N	X <sub>0</sub> N	X <sub>max</sub> N	X <sub>0</sub> N	X <sub>max</sub> N
71M	302.5	255.7	380.7	321.8	440.5	372.4	-	-
80M	495.4	404.3	625.7	510.6	719.6	587.3	791.1	645.6
90S	544.5	430.4	690.1	545.4	793.8	627.3	869.5	687.2
90L	552.7	447.8	702.2	568.9	805.7	652.8	882.6	715.1
100L	777.3	622.9	979.4	784.8	1126.4	902.6	1242.7	995.8
112M	998.3	805.1	1263.6	1019.1	1453.3	1172.0	1603.4	1293.1
132S	1138.9	890.3	1444.9	1129.5	1650.2	1290.0	1824.8	1426.5
132M	-	-	1460.6	1171.7	1672.0	1341.3	1848.8	1483.2
160M	1225.5	952.3	1545.7	1201.2	1771.5	1376.6	1956.5	1520.4
160L	1240.4	986.5	1564.5	1244.3	1793.0	1426.0	1980.3	1575.0
180M	2368.1	1882.1	2983.6	2371.3	-	-	-	-
180L	-	-	3017.2	2439.0	3453.9	2792.0	3810.1	3080.0
200L	3246.1	2680.2	4096.7	3382.6	4689.6	3872.1	5173.3	4271.5
225S	-	-	4574.0	3592.6	-	-	5762.8	4526.4
225M	3643.9	3024.9	4596.2	3646.4	5273.3	4183.6	5790.9	4594.2
250M	4057.0	3309.7	5111.1	5169.6	5863.7	4783.5	6438.9	5252.8
280S	4761.8	3933.7	6007.7	4962.9	6888.0	5690.1	7569.1	6252.7
280M	4799.8	4014.8	6056.1	5065.6	6943.7	5808.1	7630.5	6382.5
315S	5239.0	4465.1	7565.3	6254.8	8662.6	7162.0	9545.4	7891.8
315M	5297.9	4596.7	7655.6	6463.1	8766.3	7400.7	9659.8	8155.1
315L	5296.6	4595.6	7655.4	6462.9	8764.6	7399.1	9657.9	8153.5
355M	5612.0	4602.0	11100.0	9102.0	12741.0	10448.0	-	-
355L	5612.0	4658.0	11100.0	9213.0	12741.0	10575.0	-	-

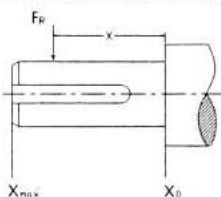

If the radial force is applied between points X<sub>0</sub> and X<sub>max</sub>, the permissible force F<sub>R</sub> can be calculated from the following formula:  $F_R = F_{X0} - X/E$  (F<sub>X0</sub> - F<sub>Xmax</sub>) E=length of shaft extension in basic version

## Permissible axial forces

The Following tables give the permissible axial forces in Newton, assuming zero radial force. The values are based on normal conditions at 50 Hz with standard bearings and calculated bearing life time of 20000 and 40000 hours.

At 60 Hz the values are to be reduced by 10%. For two-speed motors, the values are to be based on the higher speed. The permissible loads of simultaneous radial and axial forces will be supplied on request.

Given axial forces F<sub>AD</sub>, assumes D-bearing locked by means of locking ring.

### Mounting arrangement IM B3

20000 hours Ball bearings								
Motor size	2-pole		4-pole		6-pole		8-pole	
	FAD N	FAZ N	FAD N	FAZ N	FAD N	FAZ N	FAD N	FAZ N
71M	268.3	268.3	362.9	362.9	438.6	438.6	-	-
80M	434.8	434.8	592.9	592.9	712.6	712.6	804.0	804.0
90S	471.8	471.8	647.0	647.0	778.2	778.2	873.0	873.0
90L	471.8	471.8	648.9	648.9	778.2	778.2	873.0	873.0
100L	648.3	648.3	883.7	883.7	1058.3	1058.3	1202.6	1202.6
112M	843.0	843.0	1157.0	1157.0	1382.8	1382.8	1574.2	1574.2
132S	947.2	947.2	1302.3	1302.3	1542.7	1542.7	1764.0	1764.0
132M	-	-	1297.9	1297.9	1542.7	1542.7	1764.0	1764.0
160M	1017.7	1017.7	1382.1	1382.1	1651.2	1651.2	1881.4	1881.4
160L	1017.7	1017.7	1382.1	1382.1	1651.2	1651.2	1881.4	1881.4
180M	1972.9	1972.9	2665.0	2665.0	-	-	-	-
180L	-	-	2665.0	2665.0	3197.1	3197.1	3626.4	3626.4
200L	2569.6	2569.6	3489.1	3489.1	4197.9	4197.9	4754.7	4754.7
225S	-	-	3904.5	3904.5	-	-	5309.0	5309.0
225M	2873.4	2873.4	3904.5	3904.5	4718.4	4718.4	5309.0	5309.0
250M	3225.3	3225.3	4378.4	4378.4	5293.1	5293.1	5955.9	5955.9
280S	3714.9	3714.9	5007.7	5007.7	6087.7	6087.7	6924.2	6924.2
280M	3714.9	3714.9	5077.7	5077.7	6087.7	6087.7	6924.2	6924.2
315S	3963.9	3963.9	6141.0	6141.0	7292.2	7292.2	8300.9	8300.9
315M	3963.9	3963.9	6141.0	6141.0	7292.2	7292.2	8300.9	8300.9
315L	3964.7	3964.7	6143.0	6143.0	7292.2	7292.2	8300.9	8300.9
355-	5775.0	2310.0	8100.0	4050.0	9484.0	5160.0	10080.0	8420.0

40000 hours Ball bearings								
Motor size	2-pole		4-pole		6-pole		8-pole	
	FAD N	FAZ N	FAD N	FAZ N	FAD N	FAZ N	FAD N	FAZ N
71M	198.6	198.6	267.8	267.8	325.0	325.0	-	-
80M	320.6	320.6	436.1	436.1	528.4	528.4	595.6	595.6
90S	347.1	347.1	475.4	475.4	576.4	576.4	647.0	647.0
90L	341.7	341.7	477.0	477.0	576.4	576.4	647.0	647.0
100L	475.6	475.6	648.3	648.3	781.5	781.5	891.5	891.5
112M	617.1	617.1	848.0	848.0	1019.4	1019.4	1167.3	1167.3
132S	692.5	692.5	955.5	955.5	1135.8	1135.8	1306.7	1306.7
132M	-	-	952.6	952.6	1135.8	1135.8	1306.7	1306.7
160M	743.1	743.1	1019.2	1019.2	1214.3	1214.3	1391.0	1391.0
160L	743.1	743.1	1019.2	1019.2	1214.3	1214.3	1391.0	1391.0
180M	1441.7	1441.7	1972.9	1972.9	-	-	-	-
180L	-	-	1972.9	1972.9	2346.4	2346.4	2673.2	2673.2
200L	1888.2	1888.2	2575.9	2575.9	3077.9	3077.9	3499.8	3499.8
225S	-	-	2878.0	2878.0	-	-	3904.5	3904.5
225M	2117.4	2117.4	2878.0	2878.0	3457.5	3457.5	3904.5	3904.5
250M	2379.2	2379.2	3225.3	3225.3	3879.3	3879.3	4378.4	4378.4
280S	2766.7	2766.7	3721.9	3721.9	4509.5	4509.5	5077.7	5077.7
280M	2766.7	2766.7	3721.9	3721.9	4509.5	4509.5	5077.7	5077.7
315S	2965.5	2965.5	4478.5	4478.5	5357.8	5357.8	6153.3	6153.3
315M	2965.5	2965.5	4478.5	4478.5	5357.8	5357.8	6153.3	6153.3
315L	2965.8	2965.8	4479.5	4479.5	5357.8	5357.8	6153.3	6153.3
355-	4675.0	1460.0	5770.0	2030.0	6411.0	2611.0	7106.0	3366.0

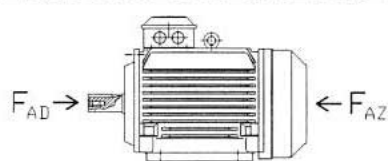

## Rating plate

For motor sizes 80 to 132 the rating plate gives one current value for the voltage area. That is the highest current that can occur within the voltage area with the given output.

ABB Motors Shanghai, China					
3 ~ mot. M2JA 132S4A Ex / EE x d II B T4					
1430 / 1700r / min			5.5 / 6.33 kW		
cos φ 0.85 / 0.86		IP 55	CI F	80 K	
V	380-420 Δ	A	11.3	50	Hz
	660-690 Y		6.52	50	
	440-480 Δ		11.23	60	
3GJA132101-ADC			AMB	°C	
6208 / C3-■ 6208 / C3			59 kg		
Q/JBQS45		No			
Cert.No. CNEEx03.502/LCIE 04 ATEX 6099					
⊕/⊕0081⊕		⊕ II 2G ⊕		Date	

For motor size 160 to 355 the rating plate is in table form giving values for speed, current and power factor for six voltages.

ABB Motors Shanghai, China					
3 ~ motor M2JA 225M4A Ex / EEx d II B T4					
IEC 225M60			↷		
S1 No					
Date		Ins.cl. F 80 K IP 55			
V	Hz	kW	r/min	A	cos φ
690 Y	50	45	1480	46.64	0.87
400 Δ	50	45	1480	80.45	0.87
660 Y	50	45	1475	48.31	0.88
380 Δ	50	45	1475	83.90	0.88
415 Δ	50	45	1480	79.37	0.85
445 Δ	50	51.8	1770	83.23	0.88
Prod.code 3GJA222301-ADC					
Cert.no CNEEx03.698 / LCIE 04 ATEX 6103					
6313 / C3		■ 6312 / C3		335 kg.	
⊕/⊕0081⊕		⊕ II 2G ⊕		Q/JBQS45 ⊕	

## Ordering information

### Sample order

When placing an order, the motor type, size and product code must be specified. The product code of the motor is composed in various way, in accordance with the following examples.

A		B		C			D, E, F		G	
M2JA		132S4A		3GJA			A D A		033	
				13	2	101	-			
				1-4	5-6	7	11	12	13	14
						8-10				15
										16

- A Motor type
- B Motor size
- C Product code
- D Mounting arrangement code
- E Voltage and frequency code
- F Generation code
- G Variant codes

## Explanation of the product code (C,D,E,F) :

### Positions 1 to 4

M2JA = Totally enclosed fan cooled squirrel cage motor with cast iron frame proof three-phase Induction Motors for Hazardous Environments

### Positions 5 and 6

#### IEC frame

07 = 71	13 = 132	25 = 250
08 = 80	16 = 160	28 = 280
09 = 90	18 = 180	31 = 315
10 = 100	20 = 200	35 = 355
11 = 112	22 = 225	

### Positions 7

#### Speed (pole pairs)

- 1 = 2 poles
- 2 = 4 poles
- 3 = 6 poles
- 4 = 8 poles

### Positions 8 to 10

Running number series

### Positions 11

-(dash)

### Code letters for supplementing the product code

A	B	D	E	F	H
380 VY 50 Hz	380 VΔ 50 Hz	380-420 VΔ 50 Hz 660-690 VY 50 Hz 440-480 VΔ 60 Hz	500 VΔ 50 Hz 575 VΔ 60 Hz	500 VY 50 Hz 575 VY 60 Hz	415 VΔ 50 Hz
S	T	U	X		
220-240 VΔ 50 Hz 380-420 VY 50 Hz 440-480 VY 60 Hz	660 VΔ 50 Hz	690 VΔ 50 Hz	Other rated Voltage, connection or frequency, max. 690 V	1480 V not stamped on sizes 160 to 355	

### Positions 12

#### Mounting arrangement

- A = Foot-mounted, top-mounted terminal box
- R = Foot-mounted, terminal box on RHS, seen from D-end
- L = Foot-mounted, terminal box on LHS, seen from D-end
- B = Flange-mounted, large flange
- C = Flange-mounted, small flange size (80-160)
- H = Foot-and flange-mounted

### Positions 13

#### Voltage and frequency code

See tables on appropriate page

### Positions 14

#### Generation code

A, B, C, ...

### Positions 15

+(plus)

### Positions 16

#### Variant codes

The product code must be, if need, followed by variant codes: Please see page 6-13.

# Flameproof motors Ex d IIB T4

Technical data for totally enclosed squirrel cage three phase motors  
IP55 IC411; Insulation class F, temperature rise class B



Output kW	Type designation	Product code	Speed r/min	Efficiency		Power factor cosφ	Current		Torque		
	M2JA	3GJA		Full load 100%	3/4 load 75%		I <sub>N</sub> A	I <sub>S</sub> I <sub>N</sub>	T <sub>N</sub> Nm	T <sub>S</sub> T <sub>N</sub>	T <sub>MAX</sub> T <sub>N</sub>
<b>3000 r/min=2 poles</b>											
							<b>400V 50Hz</b>		<b>Basic design</b>		
0.75	80M2A	081307-	2840	75	75.48	0.85	1.70	6.1	2.52	2.2	2.2
1.1	80M2B	081302-	2855	78	77.86	0.845	2.40	7.0	3.68	2.2	2.2
1.5	90S2A	091101-	2850	79	78.96	0.87	3.15	7.0	5.03	2.2	2.2
2.2	90L2A	091001-	2850	81.5	81.82	0.86	4.53	7.0	7.37	2.2	2.2
3	100L2A	101501-	2860	83	83.16	0.88	5.93	7.0	10.02	2.2	2.2
4	112M2A	111301-	2900	85	84.56	0.90	7.55	7.0	13.17	2.2	2.2
5.5	132S2A	131101-	2920	87.5	87.87	0.89	10.2	7.0	17.99	2.2	2.2
7.5	132S2B	131102-	2920	88.5	90.12	0.9	13.6	7.0	24.53	2.2	2.2
11	160M2A	161301-	2930	90	90.52	0.89	19.82	6.5	35.85	2.5	3.0
15	160M2B	161302-	2920	90	90.10	0.89	27.03	6.5	49.06	2.5	3.2
18.5	160L2A	161501-	2930	90.5	90.86	0.90	32.78	6.5	60.30	2.5	3.2
22	180M2A	181301-	2940	90.8	91.02	0.90	38.86	6.5	71.46	2.3	2.8
30	200L2A	201501-	2955	91.4	91.10	0.90	52.64	6.5	96.95	2.2	2.7
37	200L2B	201502	2955	92.2	91.83	0.90	64.36	6.5	119.6	2.3	2.7
45	225M2A	221301-	2970	92.6	92.16	0.89	78.81	7.0	144.7	2.5	2.8
55	250M2A	251301-	2960	93.4	91.7	0.89	95.5	7.5	177.4	2.4	3.0
75	280S2A	281101-	2972	94	92.3	0.90	128	7.5	241.0	2.5	3.3
90	280M2A	281301-	2972	94.3	92.4	0.90	153.5	7.5	289.2	2.3	3.2
110	315S2A	311101-	2980	94	92.16	0.91	185.6	7.1	352.5	1.8	2.2
132	315M2A	311301-	2980	94.5	92.96	0.91	221.6	7.1	423.0	1.8	2.2
160	315L2A	311501-	2979	94.6	93.52	0.92	265.4	7.2	512.9	1.8	2.2
200	315M2B	311502-	2978	94.8	93.95	0.92	331	7.2	641.4	1.8	2.2
250	355M2A	351301-	2980	95.4	94.50	0.92	411.1	7.1	802	2.3	2.8
315	355L2A	351501-	2980	96	95.25	0.92	514.8	6.9	1011	2	2.8

Output kW	Type designation	Product code	Speed r/min	Efficiency		Power factor cosφ	Current		Torque		
	M2JA	3GJA		Full load 100%	3/4 load 75%		I <sub>N</sub> A	I <sub>S</sub> I <sub>N</sub>	T <sub>N</sub> Nm	T <sub>S</sub> T <sub>N</sub>	T <sub>MAX</sub> T <sub>N</sub>
<b>1500 r/min=4 poles</b>											
							<b>400V 50Hz</b>		<b>Basic design</b>		
0.55	80M4A	082301-	1410	73.5	71.39	0.72	1.50	5.2	3.73	2.4	2.0
0.75	80M4B	082302	1415	74.5	75.15	0.7555	1.92	6.0	5.06	2.4	2.2
1.1	90S4A	092101-	1400	77.5	77.82	0.775	2.64	6.0	7.50	2.3	2.2
1.5	90L4A	092501	1390	78.5	79.16	0.798	3.49	6.0	10.31	2.3	2.2
2.2	100L4A	102501-	1430	81.5	82.32	0.805	4.84	6.0	14.69	2.3	2.2
3	100L4B	102502-	1420	82.8	82.51	0.83	6.30	6.5	10.18	2.3	2.2
4	112M4A	112301-	1430	85	84.63	0.82	8.28	6.5	26.71	2.3	2.2
5.5	132S4A	132101-	1430	86	87.07	0.85	10.9	6.5	36.73	2.3	2.2
7.5	132M4A	132301-	1440	88.5	88.26	0.85	14.4	6.5	49.74	2.3	2.2
11	160M4B	162301-	1460	89.5	90.01	0.85	20.87	6.5	71.95	2.4	2.8
15	160L4A	162501-	1460	90	90.38	0.86	27.97	6.5	98.12	2.3	2.4
18.5	180M4A	182301-	1470	91	90.88	0.86	34.12	6.5	120.2	2.3	3.0
22	180L4A	182501-	1470	92	89.98	0.88	39.22	6.5	142.9	2.4	3.0
30	200L4A	202501-	1470	92.2	91.83	0.88	53.37	6.5	194.9	2.2	2.8
37	225S4A	222101-	1480	92.6	91.16	0.85	67.85	7.0	238.8	2.2	2.8
45	225M4A	222301-	1480	92.8	91.66	0.87	80.45	7.0	290.4	2.2	2.8
55	250M4A	252301-	1480	93.4	91.3	0.87	97.7	7.0	354.9	2.4	3.0
75	280S4A	282101-	1480	94	93.9	0.87	132.4	6.5	484	2.4	2.6
90	280M4A	282301-	1480	94.3	94.6	0.87	158.3	7.2	580.7	2.3	2.8
110	315S4A	312101-	1486	94.5	93.51	0.88	191	6.9	706.9	2.1	2.2
132	315M4A	312301-	1486	94.8	94.01	0.88	228	6.9	848.3	2.1	2.2
160	315L4A	322501-	1485	94.9	94.51	0.89	273	6.9	1029	2.1	2.2
200	315L4B	312502-	1485	95	91.18	0.89	341	6.9	1286	2.1	2.2
250	355M4A	352301-	1490	95.3	94.5	0.90	420.7	6.9	1594	2.1	2.6
315	355L4A	352501-	1490	95.6	94.83	0.90	528.4	7.0	2008	2.1	2.3

# Flameproof motors Ex d IIB T4

Technical data for totally enclosed squirrel cage three phase motors  
IP55 IC411; Insulation class F, temperature rise class B



Output kW	Type designation	Product code	Speed r/min	Efficiency		Power factor cosφ	Current		Torque		
	M2JA	3GJA		Full load 100%	3/4 load 75%		I <sub>N</sub> A	I <sub>S</sub> I <sub>N</sub>	T <sub>N</sub> Nm	T <sub>S</sub> T <sub>N</sub>	T <sub>MAX</sub> T <sub>N</sub>
<b>1000 r/min=6 poles</b>											
							<b>400V 50Hz</b>		<b>Basic design</b>		
0.37	80M6A	083301-	930	63	63.22	0.66	1.29	5.0	3.80	1.9	1.8
0.55	80M6B	083302-	925	65	65.08	0.68	1.80	5.0	5.68	1.9	1.8
0.75	90S6A	093101-	920	71	70.22	0.72	2.12	5.0	7.79	2.0	2.2
1.1	90L6A	093501-	920	73	73.06	0.74	2.94	5.0	11.42	2.0	2.2
1.5	100L6A	103501-	940	76	75.28	0.765	3.72	5.5	15.24	2.0	2.2
2.2	112M6A	113301-	940	80	81.16	0.76	5.23	5.5	22.35	2.0	2.2
3	132S6A	133101-	960	82.5	83.55	0.78	6.73	6.5	29.84	2.0	2.2
4	132M6A	133301-	960	84	84.18	0.77	8.93	6.5	39.79	2.0	2.2
5.5	132M6B	133302-	960	86	85.63	0.79	11.68	6.5	54.74	2.0	2.2
7.5	160M6A	163301-	970	88	85.28	0.78	15.77	6.0	73.84	2.0	2.3
11	160L6A	163501-	970	88.5	88.56	0.78	23.00	6.0	108.3	2.2	2.3
15	180L6A	183501-	980	89	89.12	0.82	29.67	6.0	146.3	2.3	2.8
18.5	200L6A	203501-	980	90.3	90.22	0.82	36.06	6.0	180.3	2.2	2.8
22	200L6B	203502-	980	90.4	90.32	0.83	42.32	6.0	214.4	2.1	2.8
30	225M6A	223301-	980	90.8	89.20	0.78	61.14	6.6	292.3	2.2	2.8
37	250M6A	253301-	980	92.2	92.4	0.88	65.8	6.8	360.6	2.3	2.8
45	280S6A	283101-	982	92.6	91.3	0.86	81.56	6.5	437.6	2.3	2.4
55	280M6A	283301-	982	93	91.2	0.87	98.1	7.0	534.9	2.3	2.5
75	315S6A	313101-	990	93.5	93.21	0.86	135	7.4	723.5	2.0	2.0
90	315M6A	313301-	990	93.8	91.86	0.86	162	7.4	868.2	2.0	2.0
110	315L6A	313501-	990	94.3	93.52	0.87	194	6.8	1061.1	2.0	2.0
132	315L6B	313502-	990	94.5	93.82	0.87	232	6.8	1273.3	2.0	2.0
160	355M6A	353301-	990	94.7	83.85	0.89	274	6.8	1530	2.1	2.4
200	355M6B	353302-	990	94.9	93.95	0.89	341.8	6.7	1913	2.0	2.3
250	355L6A	353501-	990	95.1	94.15	0.88	421.6	6.7	2391	2.0	2.3

Output kW	Type designation	Product code	Speed r/min	Efficiency		Power factor cosφ	Current		Torque		
	M2JA	3GJA		Full load 100%	3/4 load 75%		I <sub>N</sub> A	I <sub>S</sub> I <sub>N</sub>	T <sub>N</sub> Nm	T <sub>S</sub> T <sub>N</sub>	T <sub>MAX</sub> T <sub>N</sub>
<b>750 r/min=8 poles</b>											
							<b>400V 50Hz</b>		<b>Basic design</b>		
0.18	80M8A	084301-	700	51	50.12	0.60	0.85	3.2	2.46	1.8	1.9
0.25	80M8B	084302-	700	54.5	53.28	0.60	1.11	3.6	3.41	1.8	1.9
0.37	90S8A	094101-	700	62.5	62.07	0.605	1.41	4.4	5.05	1.8	1.9
0.55	90L8A	094501-	700	63.5	63.34	0.605	2.07	4.7	7.50	1.8	2.0
0.75	100L8A	104501-	700	70	70.08	0.64	2.42	5.0	10.23	1.8	2.0
1.1	100L8B	104502-	700	71.5	70.28	0.645	3.45	5.0	15.01	1.8	2.0
1.5	112M8A	114301-	700	75	75.39	0.675	4.28	5.0	20.46	1.8	2.0
2.2	132S8A	134101-	710	81	81.78	0.70	5.60	5.5	29.59	1.8	2.0
3	132M8A	134301-	710	81	81.38	0.75	7.13	5.5	40.35	1.8	2.0
4	160M8A	164301-	720	84	83.98	0.73	9.42	5.5	53.06	2.1	2.5
5.5	160M8B	164302-	720	85.5	85.62	0.74	12.55	5.5	72.95	2.1	2.5
7.5	160L8A	164501-	720	86.5	85.82	0.74	16.91	5.5	99.5	2.1	2.5
11	180L8A	184501-	730	87.7	86.96	0.77	23.51	5.4	143.9	2.0	2.8
15	200L8A	204501-	730	89	89.38	0.76	32.01	5.5	196.2	2.3	2.8
18.5	225S8A	224101-	740	90	89.12	0.75	39.56	5.5	238.8	2.1	2.8
22	225M8A	224301-	740	90.5	89.60	0.75	46.78	6.0	283.9	2.2	2.8
30	250M8A	254301-	740	91.3	90.10	0.79	60	6.5	387.2	2.3	2.6
37	280S8A	284101-	740	91.8	91.7	0.79	73.9	6.0	477.5	2.1	2.6
45	280M8A	284301-	740	92.4	91.1	0.79	88.98	6.0	580.5	2.1	2.7
55	315S8A	314101-	740	92.8	91.52	0.82	104.3	6.9	709.8	1.8	2.0
75	315M8A	314301-	740	93	91.93	0.82	142	7.0	967.9	1.8	2.0
90	315L8A	314501-	740	93.8	93.22	0.82	168.9	7.1	1161.5	1.8	2.0
110	315L8B	314502-	740	94	92.38	0.82	206	6.4	1419.6	1.8	2.0

# Flameproof motors Ex d IIB T4

Technical data for totally enclosed squirrel cage three phase motors  
IP55 IC411; Insulation class F, temperature rise class B



Output kW	Type designation	Product code	Speed r/min	Efficiency		Current		Torque			Moment of inertia $J=GD^2/4$ kgm <sup>2</sup>	Weight kg	Sound pressure level Lp dB(A)
	M2JA	3GJA		Full load 100%	Power factor cosφ	I <sub>N</sub> A	I <sub>s</sub> I <sub>N</sub>	T <sub>N</sub> Nm	T <sub>s</sub> T <sub>N</sub>	T <sub>MAX</sub> T <sub>N</sub>			
<b>3600 r/min=2 poles</b>													
<b>460V 60Hz</b>													<b>Basic design</b>
0.86	80M2A	081301-	3410	75	0.88	1.71	6.1	2.41	2.2	2.2	0.00091	30	60
1.27	80M2B	081302-	3430	78	0.88	2.43	7.0	3.54	2.2	2.2	0.00107	31	61
1.73	90S2A	091101-	3420	79	0.87	3.30	7.0	4.83	2.2	2.2	0.00135	34	64
2.53	90L2A	091501-	3440	81.5	0.86	4.74	7.0	7.02	2.2	2.2	0.00163	40	64
3.45	100L2A	101501-	3430	83	0.89	6.13	7.0	9.61	2.2	2.2	0.00402	46	68
4.60	112M2A	101501-	3480	85	0.91	7.8	7.0	12.62	2.2	2.2	0.00671	61	70
6.33	132S2A	111301-	3510	87.5	0.90	10.55	7.0	17.22	2.2	2.2	0.01241	79	73
8.6	132M2A	131101-	3510	88.5	0.91	14.01	7.0	23.40	2.2	2.2	0.01491	84	73
12.7	132M2B	131102-	3515	91.5	0.91	20.02	6.5	34.50	2.5	3.0	0.0436	149	75
17.3	160M2A	161301-	3517	91.6	0.91	27.23	6.5	46.98	2.5	3.2	0.0551	161	75
21.3	160L2A	161302-	3520	91.8	0.91	33.46	6.5	57.79	2.5	3.2	0.06549	185	75
25.3	180L2A	161501-	3528	92.1	0.90	40.05	6.5	68.48	2.3	2.8	0.08805	216	78
34.5	200L2A	181301-	3550	91.4	0.91	54.42	6.5	92.84	2.2	2.7	0.14821	312	84
42.6	200L2B	201501-	3550	91.2	0.91	67.35	6.5	114.6	2.3	2.7	0.16822	329	84
51.8	225M2A	201502-	3560	92.2	0.90	81.91	7.0	139	2.5	2.8	0.29345	406	84
63	250M2A	221301-	3559	93.8	0.91	96.9	7.5	169.4	2.4	3.0	0.3784	488	87
86	280S2A	251301-	3565	94	0.91	131.9	7.5	230.4	2.5	3.3	0.587	630	88
104	280M2A	281101-	3565	94.3	0.91	159	7.5	278.6	2.3	3.2	0.615	700	88
127	315S2A	281301-	3576	94.5	0.92	192	7.1	339.2	1.8	2.2	1.1083	1138	91
152	315M2A	311101-	3576	95	0.92	228	7.1	405.9	1.8	2.2	1.5584	1263	91
184	315L2A	311301-	3575	95	0.93	273	7.2	491.5	1.8	2.2	1.7256	1338	91
230	315L2B	311502-	3575	95.2	0.93	341	7.2	614.4	1.8	2.2	1.9405	1400	91
287.5	355M2A	351301	3576	95.7	0.915	431	7.1	769	2.2	2.7	3.05	1798	92
362.5	355L2A	351501	3576	96.2	0.915	540	6.9	970	1.9	2.7	3.6	2158	92

Output kW	Type designation	Product code	Speed r/min	Efficiency		Current		Torque			Moment of inertia $J=GD^2/4$ kgm <sup>2</sup>	Weight kg	Sound pressure level Lp dB(A)
	M2JA	3GJA		Full load 100%	Power factor cosφ	I <sub>N</sub> A	I <sub>s</sub> I <sub>N</sub>	T <sub>N</sub> Nm	T <sub>s</sub> T <sub>N</sub>	T <sub>MAX</sub> T <sub>N</sub>			
<b>1800 r/min=4 poles</b>													
<b>460V 60Hz</b>													<b>Basic design</b>
0.63	80M4A	082301-	1690	73.5	0.75	1.50	5.2	3.56	2.4	2.0	0.00145	30	49
0.86	80M4B	082302-	1680	74.5	0.77	1.97	6.0	4.89	2.4	2.0	0.00174	31	49
1.27	90S4A	092101-	1680	77.5	0.775	2.77	6.0	7.22	2.3	2.0	0.00254	34	55
1.73	90L4A	092501-	1670	78.5	0.80	3.61	6.0	9.89	2.3	2.0	0.00317	41	55
2.53	100L4A	102501-	1720	81.5	0.82	4.97	6.0	14.05	2.3	2.0	0.00679	45	56
3.45	100L4B	102502-	1700	82.8	0.86	6.36	6.5	19.38	2.3	2.0	0.00862	52	56
4.60	112M4A	112301-	1720	85	0.825	8.61	6.5	25.54	2.3	2.0	0.01306	64	59
6.33	132S4A	132101-	1700	86	0.86	11.23	6.5	35.56	2.3	2.0	0.02673	81	62
8.6	132M4A	132301-	1730	88.5	0.86	14.83	6.5	47.47	2.3	3.8	0.03432	94	62
12.7	160M4A	162301-	1755	91	0.87	21.05	6.5	69.11	2.4	2.4	0.06543	152	69
17.3	160L4A	162501-	1752	91.6	0.88	28.16	6.5	94.30	2.3	3.0	0.09349	181	69
21.3	180M4A	182301-	1764	92.8	0.87	34.62	6.5	115.3	2.3	3.1	0.16049	214	69
25.3	180L4A	182501-	1764	93.1	0.89	40.06	6.5	137.0	2.4	2.8	0.18046	232	69
34.5	200L4A	202501-	1765	92.6	0.89	54.96	6.5	186.7	2.2	2.8	0.2819	312	74
42.6	225S4A	222101-	1770	92.6	0.85	71.02	7.0	229.8	2.2	2.8	0.37	358	76
51.8	225M4A	222301-	1770	92.8	0.88	83.23	7.0	279.5	2.2	3.0	0.42	396	76
63	250M4A	252301-	1779	93.8	0.89	99.02	7.0	338.2	2.4	2.6	0.78	563	79
86	280S4A	282101-	1775	94	0.88	136.4	6.5	462.7	2.4	2.8	1.10	668	81
104	280M4A	282301-	1775	94.3	0.88	164.4	7.2	559.5	2.3	2.2	1.35	740	81
127	315S4A	312101-	1783	95	0.89	197.1	6.9	680.2	2.1	2.2	2.8596	1163	83
152	315M4A	312301-	1783	95.1	0.89	235.6	6.9	814.1	2.1	2.2	3.1848	1288	83
184	315L4A	312501-	1782	95.3	0.90	281.5	6.9	986.1	2.1	2.2	3.6765	1313	89
230	315L4B	312502-	1782	95.4	0.90	351.5	6.9	1232.6	2.1	2.2	4.2516	1375	89
287.5	355M4A	352301	1788	95.6	0.905	436	6.9	1538	2.0	2.5	6.77	1933	90
362.5	355L4A	352501	1788	95.8	0.905	548.6	7.0	1939	2.0	2.2	8.20	2275	90

# Flameproof motors Ex d IIB T4

Technical data for totally enclosed squirrel cage three phase motors  
IP55 IC411; Insulation class F, temperature rise class B



Output kW	Type designation	Product code	Speed r/min	Efficiency		Current		Torque			Moment of inertia $J=GD^2/4$ kgm <sup>2</sup>	Weight kg	Sound pressure level Lp dB(A)
	M2JA	3GJA		Full load 100%	Power factor cos $\phi$	$I_N$ A	$I_S$ $I_N$	$T_N$ Nm	$T_S$ $T_N$	$T_{MAX}$ $T_N$			
<b>1200 r/min=6 poles</b>													
<b>460V 60Hz</b>													
<b>Basic design</b>													
0.43	80M6A	083301-	1101	63	0.67	1.34	5.0	3.72	1.9	1.9	0.00159	31	48
0.63	80M6B	083302-	1101	65	0.68	1.87	5.0	5.45	1.9	1.9	0.00196	32	48
0.86	90S6A	093101-	1105	71	0.73	2.18	5.0	7.43	2.0	2.2	0.00292	34	51
1.27	90L6A	093501-	1100	73	0.75	3.04	5.0	11.03	2.0	2.2	0.00379	41	51
1.73	100L6A	103501-	1130	77.6	0.77	3.88	5.5	14.62	2.0	2.2	0.00999	45	54
2.53	112M6A	113301-	1145	80	0.765	5.42	5.5	21.10	2.0	2.2	0.01559	59	57
3.45	132S6A	133101-	1150	82.5	0.79	6.95	6.5	28.65	2.0	2.2	0.03116	76	59
4.60	132M6A	133301-	1150	84	0.79	9.10	6.5	38.20	2.0	2.2	0.04074	86	59
6.33	132M6B	133302-	1150	83	0.8	12.07	6.5	52.57	2.0	2.2	0.05332	96	59
8.6	160M6A	163301-	1167	88	0.79	16.23	6.0	70.38	2.0	2.3	0.09231	153	64
12.7	160L6A	163501-	1166	89.9	0.80	23.17	6.0	104.0	2.2	2.3	0.12970	181	65
17.3	180L6A	183501-	1176	91.1	0.83	30.02	6.0	140.5	2.3	2.8	0.2418	225	66
21.3	200L6A	203501-	1175	90.9	0.84	36.60	6.0	173.1	2.2	2.8	0.34174	294	67
25.3	200L6B	203502-	1175	90	0.85	43.39	6.0	205.6	2.1	2.8	0.46837	308	67
34.5	225M6A	223301-	1180	90.9	0.78	63.85	6.6	279.2	2.2	2.8	0.62691	385	69
42.6	250M6A	253301-	1179	92.8	0.89	67.68	6.8	345.4	2.3	2.8	0.97	478	71
51.8	280S6A	283101-	1175	92.6	0.87	84.4	6.5	421	2.3	2.4	1.25	603	72
63	280M6A	283301-	1175	93	0.88	101	7.0	512	2.3	2.5	1.485	665	73
86	315S6A	313101-	1188	93.8	0.87	138	7.4	691.3	2.0	2.0	3.1942	1150	73
104	315M6A	313301-	1188	94	0.87	167	7.4	836.0	2.0	2.0	3.723	1263	73
127	315L6A	313501-	1188	94.5	0.88	200	6.8	1020.9	2.0	2.0	4.2564	1325	73
152	315L6B	313502-	1188	95	0.88	239	6.8	1221.9	2.0	2.0	5.1577	1400	73
184	355M6A	353301-	1188	94.9	0.9	283	6.8	1481	2	2.0	7.8	1700	75
230	355M6B	353302-	1188	95.1	0.9	353	6.7	1852	1.9	2.2	9.1	1939	75
287.5	355L6A	353501-	1198	95.3	0.9	440	6.7	2315	1.9	2.3	11.4	2571	75

Output kW	Type designation	Product code	Speed r/min	Efficiency		Current		Torque			Moment of inertia $J=GD^2/4$ kgm <sup>2</sup>	Weight kg	Sound pressure level Lp dB(A)
	M2JA	3GJA		Full load 100%	Power factor cos $\phi$	$I_N$ A	$I_S$ $I_N$	$T_N$ Nm	$T_S$ $T_N$	$T_{MAX}$ $T_N$			
<b>900 r/min=8 poles</b>													
<b>460V 60Hz</b>													
<b>Basic design</b>													
0.21	80M8A	084301-	820	53.8	0.54	0.95	3.3	2.45	1.8	1.9	0.00111	30	45
0.29	80M8B	084302-	820	58.6	0.55	1.18	3.6	3.38	1.8	1.9	0.00326	31	45
0.43	90S8A	094101-	830	61.7	0.56	1.63	4.4	4.95	1.8	1.9	0.00541	34	49
0.63	90L8A	094501-	830	63.8	0.58	2.23	4.7	7.25	1.8	1.9	0.00756	40	49
0.86	100L8A	104501-	840	70	0.64	2.52	5.0	9.78	1.8	2.0	0.00971	44	56
1.27	100L8B	104502-	840	71.5	0.65	3.59	5.0	14.44	1.8	2.0	0.01186	50	56
1.73	112M8A	114301-	850	75	0.685	4.42	5.0	19.44	1.8	2.0	0.01559	61	58
2.53	132S8A	134101-	860	81	0.71	5.77	5.5	28.09	1.8	2.0	0.03625	77	58
3.45	132M8A	134301-	860	81	0.77	7.26	5.5	38.31	1.8	2.0	0.04141	85	59
4.60	160M8A	164301-	865	88	0.76	9.03	5.5	50.79	2.1	2.5	0.0676	139	61
6.33	160M8A	164302-	866	85.9	0.76	12.72	5.5	69.81	2.1	2.5	0.09524	151	61
8.6	160L8A	464501-	865	86.5	0.77	16.94	5.5	94.90	2.1	2.5	0.12122	177	61
12.7	180L8A	184501-	876	86	0.78	24.84	5.4	138.5	2.0	2.8	0.23645	222	64
17.3	200L8A	204501-	875	89	0.78	32.70	5.5	188.8	2.3	2.8	0.37103	308	66
21.3	225S8A	224101-	890	90	0.75	41.41	5.5	228.6	2.1	2.8	0.53287	341	68
25.3	225M8A	224301-	890	90.5	0.76	48.27	6.0	271.5	2.2	2.8	0.65825	383	68
34.5	250M8A	254301-	891	92.1	0.80	61.44	6.5	369.8	2.3	2.6	0.975	490	70
42.6	280M8A	284101-	885	91.8	0.80	76.10	6.0	459.7	2.1	2.6	1.25	610	71
51.8	280S8A	284301-	885	92.4	0.80	92	6.0	559	2.1	2.7	1.485	685	71
63	315S8A	314101-	888	93.5	0.83	107	6.9	677.5	1.8	2.0	3.6842	1163	68
86	315M8A	314301-	888	93.5	0.83	145	7.0	924.9	1.8	2.0	4.9591	1263	71
104	315L8A	314501-	888	94	0.83	175	7.1	1118.5	1.8	2.0	5.8205	1338	71
127	315L8A	314502-	888	94.5	0.84	210	6.4	1365.8	1.8	2.0	6.737	1425	71

# Dimension Drawing

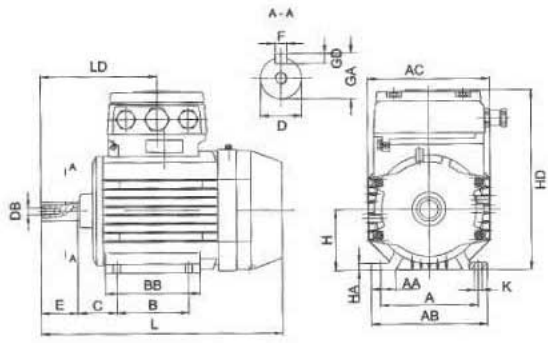

M2JA80-132

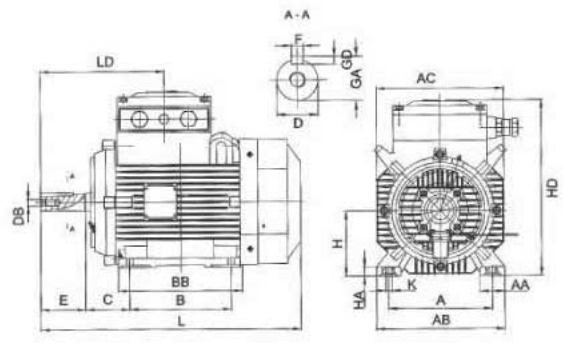

M2JA160-355

## IMB3 (IM1001)

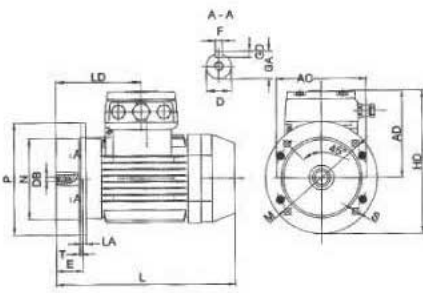

M2JA80-132

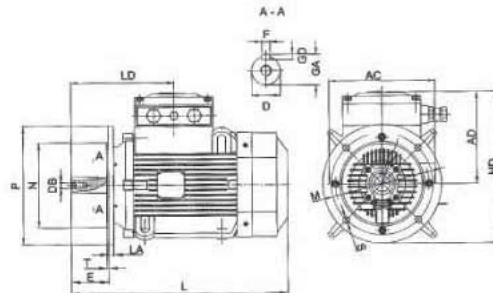

M2JA160-200

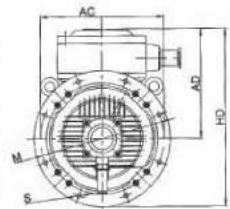

M2JA225-355

## IMB5 (IM3001)

Type	Poles	A	AA	AB	AC	B	BB	C	D	E	F	GA	GD	H	HA	HD	K	L	LD	AD	LA	M	N	P	S	R	DB	EG
80M	2-8	125	35	160	165	100	135	50	19	40	6	21.5	6	80	12	260	10	340	155	180	12	165	130	200	12	3.5	M6	16
90S	2-8	140	35	175	180	100	140	56	24	50	8	27	7	90	12	275	10	355	165	181	12	165	130	200	12	3.5	M8	19
90L	2-8	140	35	175	180	125	165	56	24	50	8	27	7	90	12	275	10	380	165	181	12	165	130	200	12	3.5	M8	19
100L	2-8	160	40	200	205	140	180	63	28	60	8	31	7	100	14	300	12	450	190	195	11	215	180	250	15	4	M10	22
112M	2-8	190	50	235	225	140	190	70	28	60	8	31	7	112	15	320	12	490	205	202	11	215	180	250	15	4	M10	22
132S	2-8	216	55	270	265	140	205	89	38	80	10	41	8	132	18	360	12	485	205	220	12	265	230	300	15	4	M12	28
132M	2-8	216	55	270	265	178	240	89	38	80	10	41	8	132	18	360	12	520	225	220	12	265	230	300	15	4	M12	28
160M	2-8	254	60	325	330	210	270	108	42	110	12	45	8	160	22	450	15	650	305	285	15	300	250	350	19	5	M16	36
160L	2-8	254	60	325	330	254	315	108	42	110	12	45	8	160	22	450	15	690	305	285	15	300	250	350	19	5	M16	36
180M	2-4	279	70	355	355	241	315	121	48	110	14	51.5	9	180	22	480	15	725	315	295	18	300	250	350	19	5	M16	36
180L	4-8	279	70	355	355	279	355	121	48	110	14	51.5	9	180	22	480	15	765	315	295	18	300	250	350	19	5	M16	36
200L	2-8	318	70	390	395	305	395	133	55	110	16	59	10	200	25	610	19	815	365	404	20	350	300	400	19	5	M20	39
225S	4-8	356	75	435	440	286	380	149	60	140	18	64	11	225	28	650	19	845	395	421	20	400	350	450	19	5	M20	39
225M	2	356	75	435	440	311	405	149	55	110	16	59	10	225	28	650	19	840	365	421	20	400	350	450	19	5	M20	39
225M	4-8	356	75	435	440	311	405	149	60	140	18	64	11	225	28	650	19	870	395	421	20	400	350	450	19	5	M20	39
250M	2	406	80	490	515	349	475	168	60	140	18	64	11	250	30	700	24	970	420	447	22	500	450	550	19	5	M20	39
250M	4-8	406	80	490	515	349	475	168	65	140	18	69	11	250	30	700	24	970	420	447	22	500	450	550	19	5	M20	39
280S	2	457	85	555	585	368	490	190	65	140	18	69	11	280	35	750	24	1030	450	470	22	500	450	550	19	5	M20	39
280S	4-8	457	85	555	585	368	490	190	75	140	20	79.5	12	280	35	750	24	1030	450	470	22	500	450	550	19	5	M20	39
280M	2	457	85	555	585	419	540	190	65	140	18	69	11	280	35	750	24	1080	450	470	22	500	450	550	19	5	M20	39
280M	4-8	508	85	555	585	419	540	190	75	140	20	79.5	12	280	35	750	24	1080	450	470	22	500	450	550	19	5	M20	39
315S	2	508	120	640	630	406	575	216	65	140	18	69	11	315	45	1010	28	1240	440	685	24	600	550	660	24	6	M20	42
315S	4-8	508	120	640	630	406	575	216	80	170	22	85	14	315	45	1010	28	1240	470	685	24	600	550	660	24	6	M20	42
315M	2	508	120	640	630	457	685	216	65	140	18	69	11	315	45	1010	28	1380	440	685	24	600	550	660	24	6	M20	42
315M	4-8	508	120	640	630	457	685	216	80	170	22	85	14	315	45	1010	28	1380	470	685	24	600	550	660	24	6	M20	42
315L	2	508	120	640	630	508	685	216	65	140	18	69	11	315	45	1010	28	1380	440	685	24	600	550	660	24	6	M20	42
315L	4-8	508	120	640	630	508	685	216	80	170	22	85	14	315	45	1010	28	1380	470	685	24	600	550	660	24	6	M20	42
355M	2	610	120	735	710	560	755	254	70	140	20	74.5	12	355	52	1080	35	1550	470	695	25	600	680	800	24	6	M20	42
355M	4-6	610	120	735	710	560	755	254	100	210	28	106	16	355	52	1080	35	1620	540	695	25	600	680	800	24	6	M24	47
355L	2	610	120	735	710	630	755	254	70	140	20	74.5	12	355	52	1080	35	1550	470	695	25	600	680	800	24	6	M20	42
355L	4-6	610	120	735	710	630	755	254	100	210	28	106	16	355	52	1080	35	1620	540	695	25	600	680	800	24	6	M24	47



## Dimension Drawing

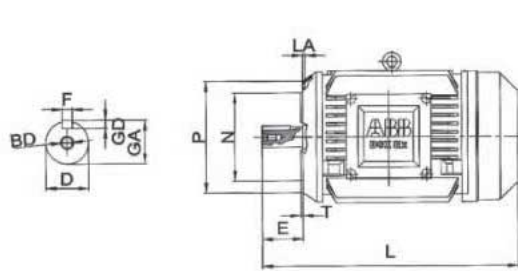

IMB14 (IM3601)

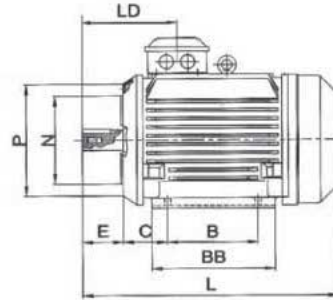
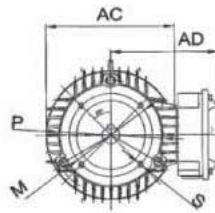

IMB34 (IM2101)

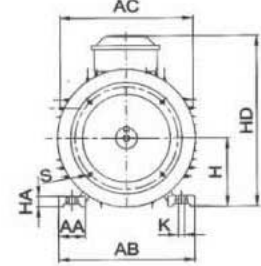

Type	Poles	A	AA	AB	AC	B	BB	C	D	E	F	GA	GD	H	HA	HD	K	L	LD	AD	LA	HE	DB	EG
80M	2-8	125	35	160	165	100	135	50	19	40	6	21.5	6	80	12	260	10	340	155	145	9	200	M6	16
90S	2-8	140	35	175	180	100	140	56	24	50	8	27	7	90	12	275	10	355	165	150	10	200	M8	19
90L	2-8	140	35	175	180	125	165	56	24	50	8	27	7	90	12	275	10	380	165	150	10	200	M8	19
100L	2-8	160	40	200	205	140	180	63	28	60	8	31	7	100	14	300	12	450	190	175	11	270	M10	22
112M	2-8	190	50	235	225	140	190	70	28	60	8	31	7	112	15	320	12	490	205	185	11	278	M10	22
132S	2-8	216	55	270	265	140	205	89	38	80	10	41	8	132	18	360	12	485	205	205	15	320	M12	28
132M	2-8	216	55	270	265	178	240	89	38	80	10	41	8	132	18	360	12	520	225	205	15	320	M12	28
160M	2-8	254	60	325	330	210	270	108	42	110	12	45	8	160	22	450	15	650	305	285	20	400	M16	36
160L	2-8	254	60	325	330	254	315	108	42	110	12	45	8	160	22	450	15	690	305	285	20	400	M16	36

Type	Poles	size	P	M	N	S	T
80M	2-8	C120	120	100	80	M6	3
80M	2-8	C160	160	130	110	M8	3.5
90S	2-8	C140	140	115	95	M8	3
90S	2-8	C160	160	130	110	M8	3.5
90L	2-8	C140	140	115	95	M8	3
90L	2-8	C160	160	130	110	M8	3.5
100L	2-8	C160	160	130	110	M8	3.5
100L	2-8	C200	200	165	130	M10	3.5
112M	2-8	C160	160	130	110	M8	3.5
112M	2-8	C200	200	165	130	M10	3.5
132S	2-8	C200	200	165	130	M10	3.5
132M	2-8	C200	200	165	130	M10	3.5
160M	2-8	C250	250	215	180	M12	4
160L	2-8	C250	250	215	180	M12	4

# M2000 Flame proof motors – totally enclosed squirrel cage three phase motors

## Lubrication :

Motor sizes 80-132 are fitted with bearing that are regreased for life. For size 160-355 are equipped with bearing that are regreasable via grease nipples.

## Insulation :

Phase insulation and generous electrical Dimensioning give the motor a high overload capacity. (Suitable for frequency converter drive)

## Endshields, flanges :

The endshield of Ex d and different variants of flanges are of cast iron.

## Bearings :

The motor size 80-90 are fitted with enclosed 2RS1 bearing as standard. The motor sizes 100-132 are fitted with enclosed DDU C3 bearing as standard. Sizes 160-355 have regreasable bearings as standard. Modern design secure high load capacity run.

## Terminal box :

The spacious terminal box of cast iron makes the motor quick and easy to connect. The terminal box of motor size 80-355 can be turned 4x90 degrees. As standard the terminal box is on top of the motor. (terminal box side mounted is not acceptable).

## Rotor winding :

The rotor winding is made of pressure diecast aluminium, a design that provides high starting capacity and low noise level.

## Low noise level :

The high efficiency of the motor means that a smaller, quieter fan can be used.

## Corrosion protection :

Effective corrosion protection means that the motor can be used in all environments.



# Visit our web site

www.abb.com/motors&generators

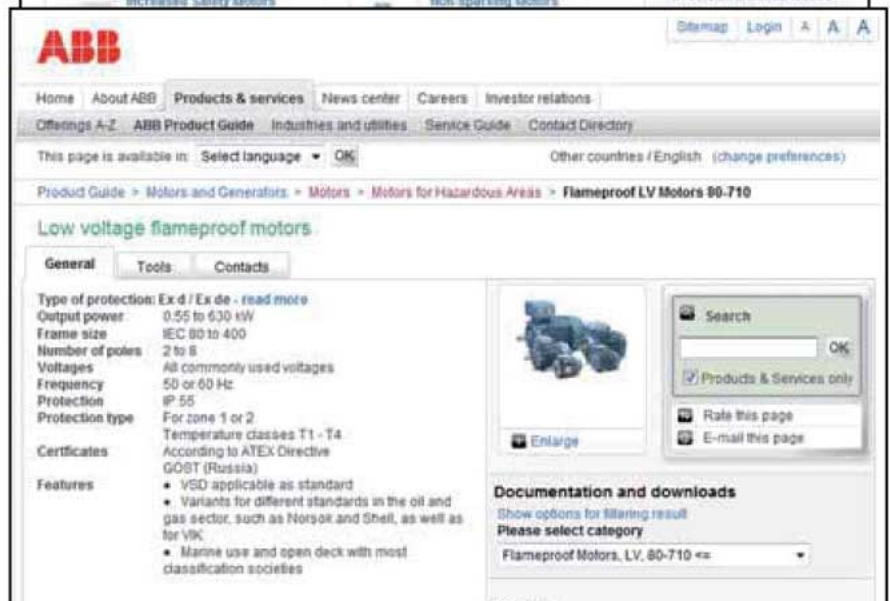
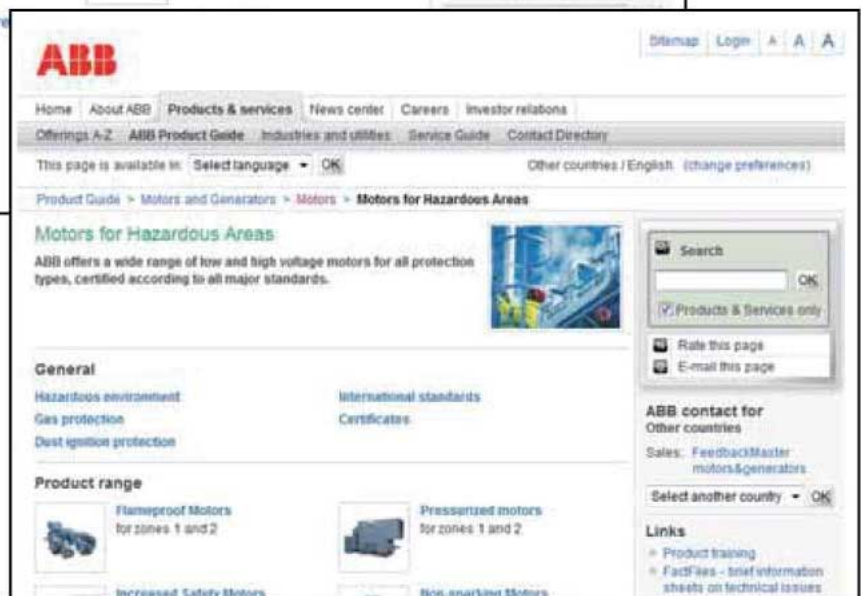
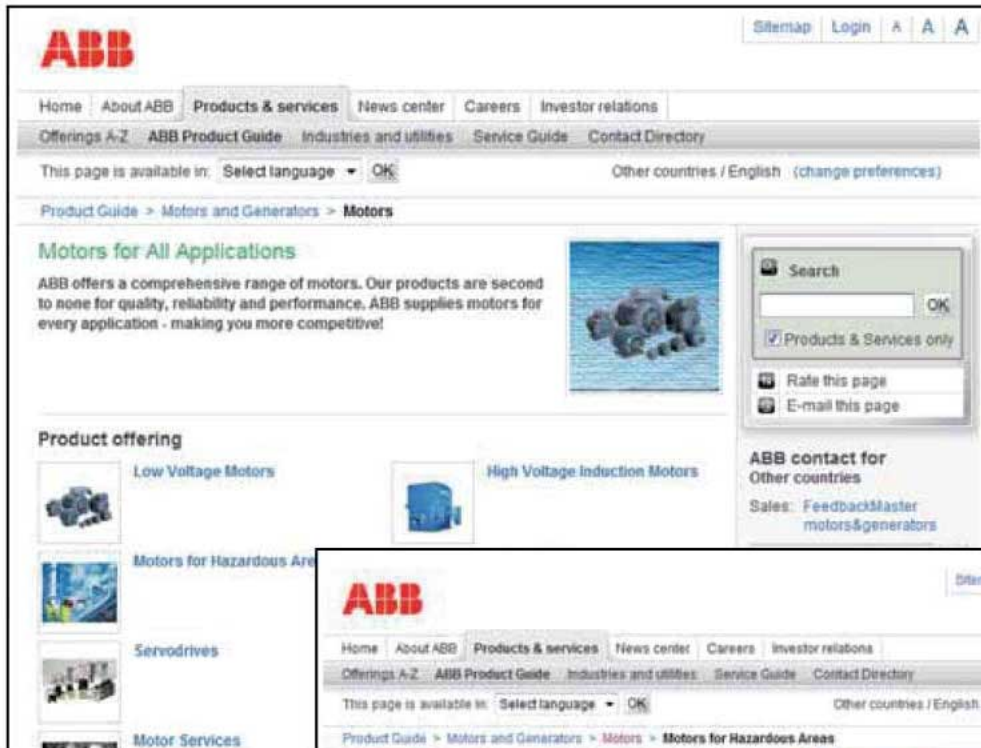

## Motors and Generators

### => Motors

#### => Low Voltage Motors

General purpose motors

Process performance motors

#### => Motors for hazardous areas

Hazardous environment

International standards

Certificates

Gas protection

Dust ignition protection

Product range

Marine motors

NEMA motors

Permanent magnet motors

Smoke venting motors

Water cooled motors

Fan application motors

Roller table motors

### => Generators

Wind turbine generators

# Low Voltage Motors

Manufacturing sites (\*) and some of the larger sales companies.

## Australia

ABB Australia Pty Ltd  
601 Blackburn Road  
Notting Hill VIC 3168  
Tel: +61 (0) 8544 0000  
Fax: +61 (0) 8544 0001

## Austria

ABB AG  
Clemens Holzmeisterstrasse 4  
AT-1810 Wien  
Tel: +43 (0) 1 601 090  
Fax: +43 (0) 1 601 09 8305

## Belgium

Asea Brown Boveri S.A.-N.V.  
Hoge Wei 27  
BE-1930 Zaventem  
Tel: +32 (0) 2 718 6311  
Fax: +32 (0) 2 718 6657

## Canada

ABB Inc., BA Electrical Machines  
10300 Henri-Bourassa Blvd, West,  
Saint-Laurent, Quebec  
Canada H4S 1N6  
Tel: +1 514 832-6583  
Fax: +1 514 332-0609

## China\*

ABB Shanghai Motors Co., Ltd.  
88 Tianning Road  
Minhang(Economical and Techno-  
logical Development Zone)  
200245 Shanghai  
Tel: +86 21 5472 3133  
Fax: +86 21 5472 5025

## Chile

Asea Brown Boveri S.A.  
P.O.Box 581-3  
Santiago  
Tel: +56 (0) 2 5447 100  
Fax: +56 (0) 2 5447 405

## Denmark

ABB A/S  
Automation Products  
Emil Neckelmanns Vej 14  
DK-5220 Odense SO  
Tel: +45 65 47 70 70  
Fax: +45 65 47 77 13

## Finland\*

ABB Oy  
Motors  
P.O.Box 633  
FI-65101 Vaasa  
Tel: +358 (0) 10 22 11  
Fax: +358 (0) 10 22 47372

## France

ABB Entrellec  
ZA La Boisse BP 90145  
300 Rue des Prés-Seigneurs  
FR-01124 Montluel Cedex  
Tel: +33 4 37 40 40 00  
Fax: +33 4 37 40 40 72

## Germany

ABB Automation Products GmbH  
Motors & Drives  
Wallstaedter Strasse 59  
DE-68526 Ladenburg  
Tel: +49 (0) 6203 717 717  
Fax: +49 (0) 6203 717 600

## Hong Kong

ABB (Hong Kong) Ltd.  
Tai Po Industrial Estate,  
3 Dai Hei Street,  
Tai Po, New Territories,  
Hong Kong  
Tel: +852 2929 3838  
Fax: +852 2929 3505

## India\*

ABB Ltd.  
32, Industrial Area, N.I.T  
Faridabad 121 001  
Tel: +91 (0) 129 502 3001  
Fax: +91 (0) 129 502 3006

## Indonesia

PT. ABB Sakti Industri  
JL. Gajah Tunggal Km.1  
Jatiuwung, Tangerang 15136  
Banten, Indonesia  
Tel: + 62 21 590 9955  
Fax: + 62 21 590 0115 - 6

## Ireland

Asea Brown Boveri Ltd  
Components Division  
Belgard Road  
Tallaght, Dublin 24  
Tel: +353 (0) 1 405 7300  
Fax: +353 (0) 1 405 7327

## Italy\*

ABB SACE SpA  
LV Motors  
Via dell' Industria 18  
IT-20010 Vittuone, Milano  
Tel: +39 02 90341  
Fax: +39 02 9034 7289

## Japan

ABB K.K.  
26-1 Cerulean Tower  
Sakuragaoka-cho, Shibuya-ku  
Tokyo 150-8512  
Tel: +81 (0) 3 578 46251  
Fax: +81 (0) 3 578 46260

## Korea

ABB Korea Ltd.  
7-9fl, Oksan Bldg., 157-33  
Sungshung-dong, Kangnam-ku  
Seoul  
Tel: +82 2 528 2329  
Fax: +82 2 528 2338

## Malaysia

ABB Malaysia Sdn. Bhd.  
Lot 608, Jalan SS 13/1K  
47500 Subang Jaya, Selangor  
Tel: +60 3 5628 4888  
Fax: +60 3 5631 2926

## Mexico

ABB México, S.A. de C.V.  
Apartado Postal 111  
CP 54000 Tlalnequiltla  
Edo. de México, México  
Tel: +52 5 328 1400  
Fax: +52 5 390 3720

## The Netherlands

ABB B.V.  
Dept. LV motors (APP2R)  
P.O.Box 301  
NL-3000 AH Rotterdam  
Tel: +31 (0) 10 4078 879  
Fax: +31 (0) 10 4078 345

## Norway

ABB AS  
P.O.Box 154 Vollebakk  
NO-0520 Oslo  
Tel: +47 22 872 000  
Fax: +47 22 872 541

## Russia

ABB Industrial & Building Systems  
Ltd.  
Business Centre "Krugozor"  
Obrucheva 30/1, Building 2  
Moscow 117861  
Tel: +7 495 960 2200, 956 93 93  
Fax: +7 495 960 2209, 230 63 46

## Singapore

ABB Industry Pte Ltd  
2 Ayer Rajah Crescent  
Singapore 139935  
Tel: +65 6776 5711  
Fax: +65 6778 0222

## Spain\*

Asea Brown Boveri S.A.  
Automation Products - Fábrica  
Motores  
P.O.Box 81  
ES-08200 Sabadell  
Tel: +34 93 728 8500  
Fax: +34 93 728 8741

## Sweden\*

ABB AB  
LV Motors  
SE-721 70 Västerås  
Tel: +46 (0) 21 329 000  
Fax: +46 (0) 21 329 140

## Switzerland

ABB Schweiz AG  
Normelec/CMC Components  
Motors&Drives  
Badenerstrasse 790  
Postfach  
CH-8048 Zürich  
Tel: +41 (0) 58 586 0000  
Fax: +41 (0) 58 586 0603

## Taiwan

ABB Ltd.  
6F, No. 126, Nanking East Road,  
Section 4i  
Taipei, 105 Taiwan, R.O.C.  
Tel: +886 (0) 2 2577 6090  
Fax: +886 (0) 2 2577 9467

## Thailand

ABB Limited (Thailand)  
161/1 SG Tower,  
Soi Mahadlekluang 3,  
Rajdamri, Bangkok 10330  
Tel: +66 2 665 1000  
Fax: +66 2 665 1042

## The United Kingdom

ABB Ltd  
Drives, Motors and Machines  
Daresbury Park  
Daresbury, Warrington  
Cheshire, WA4 4BT  
Tel: +44 (0) 1925 741 111  
Fax: +44 (0) 1925 741 212

## USA

ABB Inc.  
Low Voltage Motors  
16250 W. Glendale Drive  
New Berlin, WI 53151  
Tel: +1 262 785 3200  
Fax: +1 262 780 8888

## Venezuela

Asea Brown Boveri S.A.  
P.O.Box 6649  
Carmelitas,  
Caracas 1010A  
Tel: +58 (0) 2 238 2422  
Fax: +58 (0) 2 239 6383

